

BM 4", BM 6", BM 8" BMB 4", BMB 6", BMB 8"

- Ⓜ Installation and operating instructions
- Ⓜ Montage- und Betriebsanleitung
- Ⓜ Notice d'installation et d'entretien
- Ⓜ Istruzioni di installazione e funzionamento
- Ⓜ Instrucciones de instalación y funcionamiento
- Ⓜ Instruções de instalação e funcionamento
- Ⓜ Οδηγίες εγκατάστασης και λειτουργίας
- Ⓜ Installatie- en bedieningsinstructies
- Ⓜ Monterings- och driftsinstruktion
- Ⓜ Asennus- ja käyttöohjeet
- Ⓜ Monterings- og driftsinstruktion



Declaration of Conformity

We **Grundfos** declare under our sole responsibility that the products **BM 4"**, **BM 6"**, **BM 8"**, **BMB 4"**, **BMB 6"** and **BMB 8"**, to which this declaration relates, are in conformity with the Council Directives on the approximation of the laws of the EC Member States relating to

- Machinery (98/37/EC).
Standard used: EN ISO 12100.
- Electromagnetic compatibility (89/336/EEC).
Standards used: EN 61 000-6-2 and EN 61 000-6-3.
- Electrical equipment designed for use within certain voltage limits (73/23/EEC) [95].
Standards used: EN 60 335-1, EN 60 335-2-41 and EN 60 034.

Konformitätserklärung

Wir **Grundfos** erklären in alleiniger Verantwortung, daß die Produkte **BM 4"**, **BM 6"**, **BM 8"**, **BMB 4"**, **BMB 6"** und **BMB 8"**, auf die sich diese Erklärung bezieht, mit den folgenden Richtlinien des Rates zur Angleichung der Rechtsvorschriften der EG-Mitgliedstaaten übereinstimmen:

- Maschinen (98/37/EG).
Norm, die verwendet wurde: EN ISO 12100.
- Elektromagnetische Verträglichkeit (89/336/EEG).
Normen, die verwendet wurden: EN 61 000-6-2 und EN 61 000-6-3.
- Elektrische Betriebsmittel zur Verwendung innerhalb bestimmter Spannungsgrenzen (73/23/EEG) [95].
Normen, die verwendet wurden: EN 60 335-1, EN 60 335-2-41 und EN 60 034.

Déclaration de Conformité

Nous **Grundfos** déclarons sous notre seule responsabilité que les produits **BM 4"**, **BM 6"**, **BM 8"**, **BMB 4"**, **BMB 6"** et **BMB 8"** auxquels se réfère cette déclaration sont conformes aux Directives du Conseil concernant le rapprochement des législations des Etats membres CE relatives à

- Machines (98/37/CE).
Standard utilisé: EN ISO 12100.
- Compatibilité électromagnétique (89/336/CEE).
Standards utilisés: EN 61 000-6-2 et EN 61 000-6-3.
- Matériel électrique destiné à employer dans certaines limites de tension (73/23/CEE) [95].
Standards utilisés: EN 60 335-1, EN 60 335-2-41 et EN 60 034.

Dichiarazione di Conformità

Noi **Grundfos** dichiariamo sotto la nostra esclusiva responsabilità che i prodotti **BM 4"**, **BM 6"**, **BM 8"**, **BMB 4"**, **BMB 6"** e **BMB 8"**, ai quali questa dichiarazione si riferisce, sono conformi alle Direttive del consiglio concernenti il ravvicinamento delle legislazioni degli Stati membri CE relative a

- Macchine (98/37/CE).
Standard usato: EN ISO 12100.
- Compatibilità elettromagnetica (89/336/CEE).
Standard usati: EN 61 000-6-2 e EN 61 000-6-3.
- Materiale elettrico destinato ad essere utilizzato entro certi limiti di tensione (73/23/CEE) [95].
Standard usati: EN 60 335-1, EN 60 335-2-41 e EN 60 034.

Declaración de Conformidad

Nosotros **Grundfos** declaramos bajo nuestra única responsabilidad que los productos **BM 4"**, **BM 6"**, **BM 8"**, **BMB 4"**, **BMB 6"** y **BMB 8"** a los cuales se refiere esta declaración son conformes con las Directivas del Consejo relativas a la aproximación de las legislaciones de los Estados Miembros de la CE sobre

- Máquinas (98/37/CE).
Norma aplicada: EN ISO 12100.
- Compatibilidad electromagnética (89/336/CEE).
Normas aplicadas: EN 61 000-6-2 y EN 61 000-6-3.
- Material eléctrico destinado a utilizarse con determinados límites de tensión (73/23/CEE) [95].
Normas aplicadas: EN 60 335-1, EN 60 335-2-41 y EN 60 034.

Declaração de Conformidade

Nós **Grundfos** declaramos sob nossa única responsabilidade que os produtos **BM 4"**, **BM 6"**, **BM 8"**, **BMB 4"**, **BMB 6"** e **BMB 8"** aos quais se refere esta declaração estão em conformidade com as Directivas do Conselho das Comunidades Europeias relativas à aproximação das legislações dos Estados Membros respeitantes à

- Máquinas (98/37/CE).
Norma utilizada: EN ISO 12100.
- Compatibilidade electromagnética (89/336/CEE).
Normas utilizadas: EN 61 000-6-2 e EN 61 000-6-3.
- Material eléctrico destinado a ser utilizado dentro de certos limites de tensão (73/23/CEE) [95].
Normas utilizadas: EN 60 335-1, EN 60 335-2-41 e EN 60 034.

Δήλωση Συμμόρφωσης

Εμείς η **Grundfos** δηλώνουμε με αποκλειστικά δική μας ευθύνη ότι τα προϊόντα **BM 4"**, **BM 6"**, **BM 8"**, **BMB 4"**, **BMB 6"** και **BMB 8"** συμμορφώνονται με την Οδηγία του Συμβουλίου επί της σύγκλισης των νόμων των Κρατών Μελών της Ευρωπαϊκής Ένωσης σε σχέση με τα

- Μηχανήματα (98/37/ΕΚ).
Πρότυπο που χρησιμοποιήθηκε: EN ISO 12100.
- Ηλεκτρομαγνητική συμβατότητα (89/336/ΕΕΚ).
Πρότυπα που χρησιμοποιήθηκαν: EN 61 000-6-2 και EN 61 000-6-3.
- Ηλεκτρικές συσκευές σχεδιασμένες για χρήση εντός ορισμένων ορίων ηλεκτρικής τάσης (73/23/ΕΕΚ) [95].
Πρότυπα που χρησιμοποιήθηκαν: EN 60 335-1, EN 60 335-2-41 και EN 60 034.

Overeenkomstigheidsverklaring

Wij **Grundfos** verklaren geheel onder eigen verantwoordelijkheid dat de producten **BM 4"**, **BM 6"**, **BM 8"**, **BMB 4"**, **BMB 6"** en **BMB 8"** waarop deze verklaring betrekking heeft in overeenstemming zijn met de Richtlijnen van de Raad inzake de onderlinge aanpassing van de wetgevingen van de Lid-Staten betreffende

- Machines (98/37/EG).
Norm: EN ISO 12100.
- Elektromagnetische compatibiliteit (89/336/EEG).
Normen: EN 61 000-6-2 en EN 61 000-6-3.
- Elektrisch materiaal bestemd voor gebruik binnen bepaalde spanningsgrenzen (73/23/EEG) [95].
Normen: EN 60 335-1, EN 60 335-2-41 en EN 60 034.

Försäkran om överensstämmelse

Vi **Grundfos** försäkrar under ansvar, att produkterna **BM 4"**, **BM 6"**, **BM 8"**, **BMB 4"**, **BMB 6"** och **BMB 8"**, som omfattas av denna försäkran, är i överensstämmelse med Rådets Direktiv om inbördes närmande till EU-medlemsstaternas lagstiftning, avseende

- Maskinell utrustning (98/37/EC).
Använd standard: EN ISO 12100.
- Elektromagnetisk kompatibilitet (89/336/EC).
Använda standarder: EN 61 000-6-2 och EN 61 000-6-3.
- Elektrisk material avsedd för användning inom vissa spänninggränser (73/23/EC) [95].
Använda standarder: EN 60 335-1, EN 60 335-2-41 och EN 60 034.

Vastaavuusvakuutus

Me **Grundfos** vakuutamme yksin vastuullisesti, että tuotteet **BM 4"**, **BM 6"**, **BM 8"**, **BMB 4"**, **BMB 6"** ja **BMB 8"**, jota tämä vakuutus koskee, noudattavat direktiivejä jotka käsittelevät EY:n jäsenvaltioiden koneellisia laitteita koskevien lakien yhdenmukaisuutta seur.:

- Koneet (98/37/EY).
Käytetty standardi: EN ISO 12100.
- Elektromagneettinen vastaavuus (89/336/EY).
Käytetyt standardit: EN 61 000-6-2 ja EN 61 000-6-3.
- Määrättyjen jänniterajoitusten puitteissa käytettävät sähköiset laitteet (73/23/EY) [95].
Käytetyt standardit: EN 60 335-1, EN 60 335-2-41 ja EN 60 034.

Overensstemmelseserklæring

Vi **Grundfos** erklærer under ansvar, at produkterne **BM 4"**, **BM 6"**, **BM 8"**, **BMB 4"**, **BMB 6"** og **BMB 8"**, som denne erklæring omhandler, er i overensstemmelse med Rådets direktiver om indbyrdes tilnærmelse til EF medlemsstaternes lovgivning om

- Maskiner (98/37/EF).
Anvendt standard: EN ISO 12100.
- Elektromagnetisk kompatibilitet (89/336/EØF).
Anvendte standarder: EN 61 000-6-2 og EN 61 000-6-3.
- Elektrisk materiel bestemt til anvendelse inden for visse spændingsgrænser (73/23/EØF) [95].
Anvendte standarder: EN 60 335-1, EN 60 335-2-41 og EN 60 034.

Bjerringbro, 1st July 2004

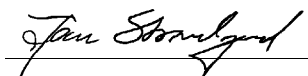

Jan Strandgaard
Technical Manager

BM 4", BM 6", BM 8" BMB 4", BMB 6", BMB 8"

Installation and operating instructions	Page	4	
Montage- und Betriebsanleitung	Seite	12	
Notice d'installation et d'entretien	Page	21	
Istruzioni di installazione e funzionamento	Pag.	29	
Instrucciones de instalación y funcionamiento	Pág.	37	
Instruções de instalação e funcionamento	Pág.	45	
Οδηγίες εγκατάστασης και λειτουργίας	Σελίδα	53	
Installatie- en bedieningsinstructies	Pag.	61	
Monterings- och driftsinstruktion	Sida	69	
Asennus- ja käyttöohjeet	Sivu	77	
Monterings- og driftsinstruktion	Side	85	

CONTENTS

	Page
1. General description	4
1.1 Pumped liquids	4
1.2 Sound pressure level	4
2. Delivery, transportation and storage	4
2.1 Frost protection	4
3. Preparation	4
4. Installation	5
4.1 Booster modules connected in series and in parallel	5
5. Pipe connection	6
6. Electrical connection	6
6.1 Frequency converter operation	7
7. Motor protection	7
7.1 Setting of motor starter	7
8. Before starting the booster module(s)	7
9. Operation	8
9.1 Limitations to operation	8
10. Automatic monitoring devices	9
11. Checking of operation	9
12. Fault finding chart	10
13. Manuals	10
14. Checking of motor and cable	11
15. Disposal	11



Before beginning installation procedures, these installation and operating instructions should be studied carefully. The installation and operation should also be in accordance with local regulations and accepted codes of good practice.

1. General description

Grundfos BM and BMB booster modules are designed for pressure boosting, liquid transfer and circulation in systems with a high static pressure.

1.1 Pumped liquids

Thin, non-explosive liquids, not containing abrasive particles or fibres. The liquid must not attack the pump materials chemically and mechanically.



The booster modules must not be used for the pumping of inflammable liquids such as diesel oil, petrol or similar liquids.

1.2 Sound pressure level

The sound pressure level of the booster modules BM 4", BM 6", BMB 4" and BMB 6" is lower than 70 dB(A).

The sound pressure level of the booster modules BM 8" and BMB 8" is lower than 80 dB(A).

2. Delivery, transportation and storage

Delivery:

The booster modules are supplied from the factory in proper packing in which they should remain until they are to be installed. The modules are ready for installation.

Transportation and storage:

During transportation and storage, the booster modules may only be placed in the positions shown in fig. 1.

Before storage, the booster modules should be flushed through with clean freshwater, see section 9.1.2 *Flushing of the booster module*.

Fig. 1

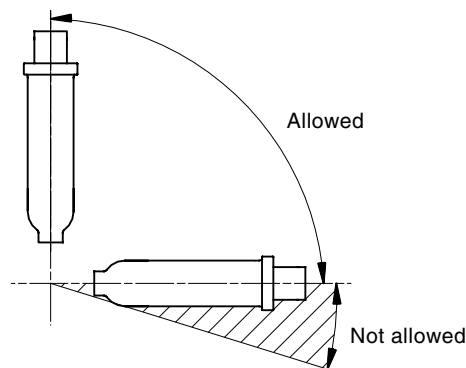

TM01 1282 4197

Note: If the module has been stored for more than one year, the motor liquid must be checked and refilled, if required.

Motors of **standard modules** are factory-filled with a Grundfos motor liquid, SML-2, which is frost-proof down to -20°C.

Motors of **modules in special version** may be filled with demineralized water, i.e. not frost-proof.

2.1 Frost protection

If the module has to be stored, it must be stored on a frost-free location, or it must be ensured that the motor liquid is frost-proof.

3. Preparation

Before installation, the following checks should be made:

- 1. Check for transport damages**
Make sure that the module has not been damaged during transportation.
- 2. Type of module**
Check that the type designation given on the nameplate fitted to the sleeve corresponds to order.
- 3. Electricity supply**
The motor voltage and frequency are marked on the nameplate. Make sure that the motor is suitable for the electricity supply on which it will be used.
- 4. Liquid in motor**
If a module has been stored for more than one year, check the motor liquid and refill, if required. Contact Grundfos.
If a module is supplied for a special system, the motor may be supplied without liquid or with demineralized water. See section 2. *Delivery, transportation and storage*.

Fig. 2

Versions:

BM 4"

Straight version

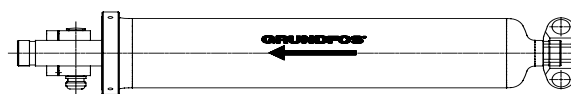

TM00 3793 4698

Bent version



TM00 3794 4698

BM 6"

BM 6" is only available in straight version.

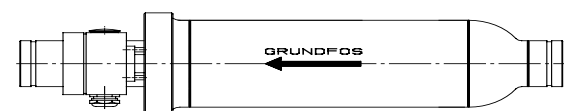

TM00 4019 4698

BM 8"

BM 8" is only available in straight version.

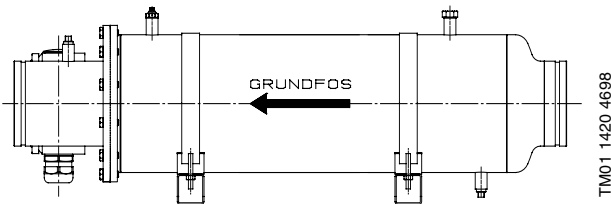

BMB 4"

Straight version

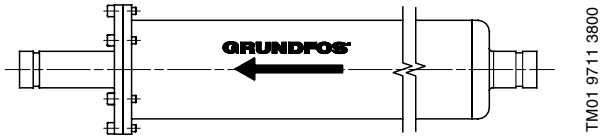

Bent version

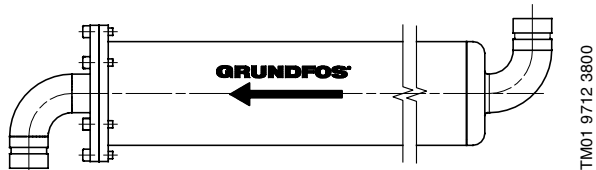

BMB 6"

BMB 6" is only available in straight version.



BMB 8"

BMB 8" is only available in straight version.



4. Installation

Grundfos booster modules are supplied as standard without built-in non-return valve, but they are available with non-return valve. For the application of a non-return valve, see fig. 6.

In systems involving the risk of water hammer in connection with start/stop, the necessary measures must be taken to reduce this risk.

The booster modules are suitable for both vertical and horizontal installation, however, the discharge port **should never** fall below the horizontal plane, see fig. 3.

An arrow on the module sleeve shows the direction of flow of liquid through the module, see fig. 2.

The module is fastened by means of clamps, see fig. 4.



Note that the module has an uneven weight distribution. Because of the motor, the largest weight will be in the first third of the sleeve (when seen from the suction port).

Fig. 3

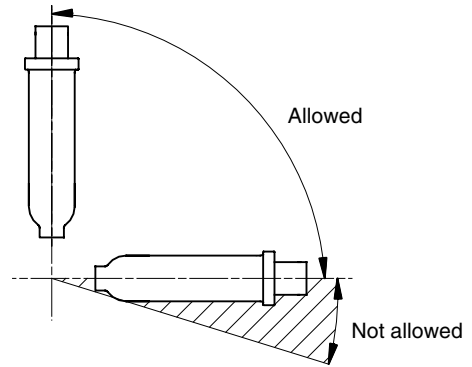
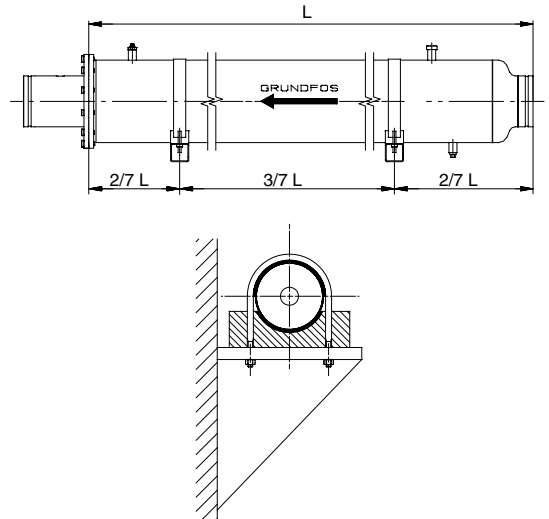

Fig. 4



4.1 Booster modules connected in series and in parallel

- For modules connected in series, mounted above each other, it is recommended to connect the pipes as shown in fig. 5.
- For modules connected in parallel, mounted above each other, it is recommended to connect the pipes as shown in fig. 6. This layout ensures that the modules are filled with water before starting.
- When modules are connected in series and parallel, mounted above each other, it is recommended to connect the pipes as shown in fig. 7.
- For modules connected in series and fitted with a bypass, mounted above each other, it is recommended to connect the pipes as shown in fig. 8.

Fig. 5 Booster system with four modules connected in series, mounted above each other.

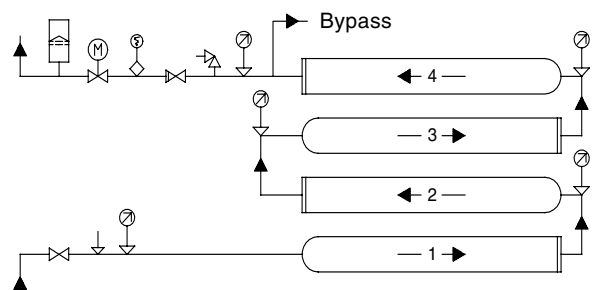

TM01 1282 4197

TM02 5911 4002 / TM00 4041 4197

TM00 3760 1902

Fig. 6 Booster system with four modules connected in parallel, mounted above each other.

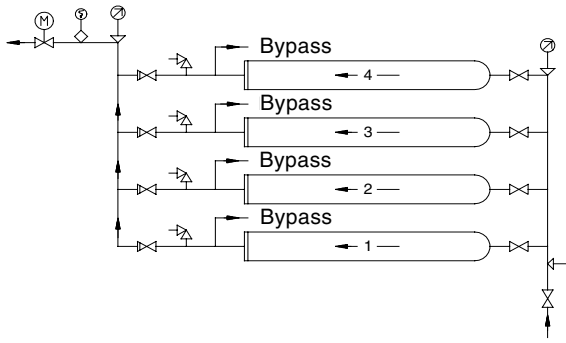

TM00 3761 1902

Fig. 7 Booster system with two modules connected in series and in parallel, mounted above each other.

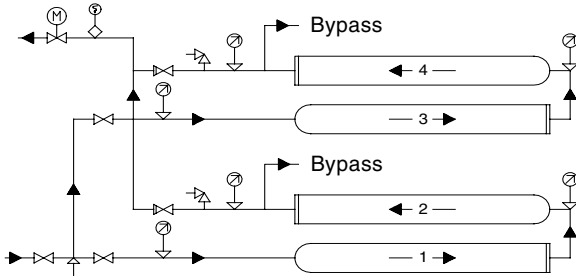

TM00 3762 1902

Fig. 8 Booster system with four modules connected in series with bypass, mounted above each other.

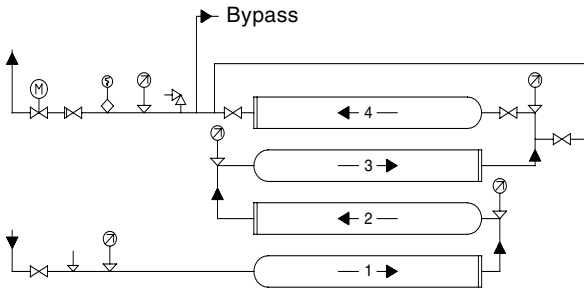

TM00 3763 1902

- = Air escape valve
- = Isolating valve
- = Non-return valve
- = Pressure switch
- = Flow switch
- = Pressure gauge
- = Motor-operated valve
- = Diaphragm tank

Note: As venting problems may arise in such installations, it is advisable to install suitable air vent devices.

5. Pipe connection

The booster modules are fitted with clamp liners for Victaulic/PJE clamp couplings on the suction and discharge sides, see fig. 9.

Fig. 9

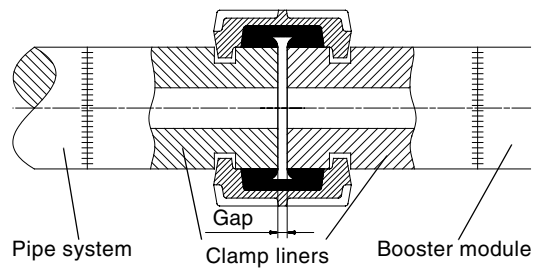

TM01 1066 3597

Size	Type	Victaulic coupling	Gap [mm]
BM 4"	BM 3A - BM 8A	1 1/4" ø42 mm	1
BM 6"	BM 17 - BM 60	3" ø89 mm	3
BM 8"	BM 30 - BM 46	3" ø89 mm	3
BM 8"	BM 60	4" ø114 mm	6
BM 8"	BM 77 - BM 95	5" ø139 mm	6
BM 8"	BM 125	6" ø168 mm	6
BMB 4"	BMB 3A - BMB 8A	1 1/4" ø42 mm	1
BMB 6"	BMB 17 - BMB 60	3" ø89 mm	3
BMB 8"	BMB 30 - BMB 46	3" ø89 mm	3
BMB 8"	BMB 60	4" ø114 mm	6
BMB 8"	BMB 77 - BMB 95	5" ø139 mm	6
BMB 8"	BMB 125	6" ø168 mm	6

6. Electrical connection

The electrical connection should be carried out by an authorized electrician in accordance with local regulations.

Before making any electrical connections, make sure that the electricity supply has been switched off and that it cannot be accidentally switched on.



The booster modules must be connected to an external mains switch.

The pump must be earthed.

The required voltage quality measured at the module terminals is -10%/+6% of the nominal voltage during continuous operation (including variation in the supply voltage and losses in cables).

It must be checked that there is voltage symmetry in the electricity supply lines, i.e. approximately same difference of voltage between the individual phases. See also section 14. *Checking of motor and cable*, point 1.

In order that the modules meet the EC EMC Directive (89/336/EEC), a 0.47 µF capacitor (in accordance with IEC 384-14) must always be connected over the two phases to which the temperature transmitter is connected, see fig. 10.

Fig. 10

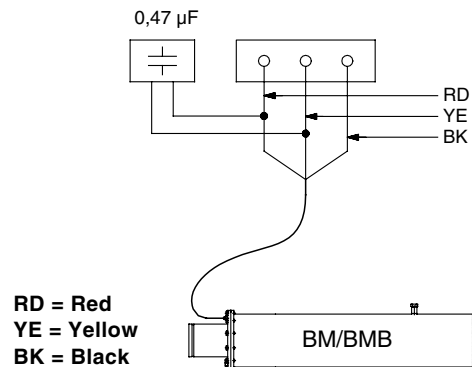

RD = Red
YE = Yellow
BK = Black

TM02 5255 2402

The electrical connections must be made close to the flange (fig. 11), either by means of a terminal box (figs. 12 and 13) or a cable termination kit.

Fig. 11

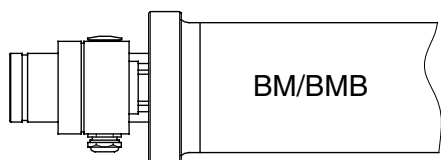

TM02 02 5256 2402

Fig. 12

**BM 4", BM 6", BM 8",
BMB 4", BMB 6" and BMB 8"**
Direct-on-line

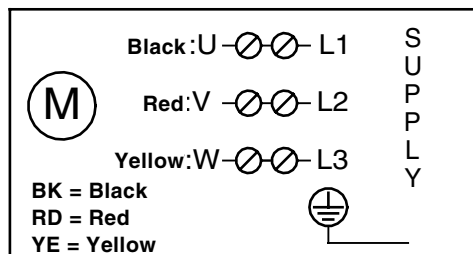

TM00 4035 1694

Fig. 13

BM 6", BM 8", BMB 6" and BMB 8"
Star-delta starting

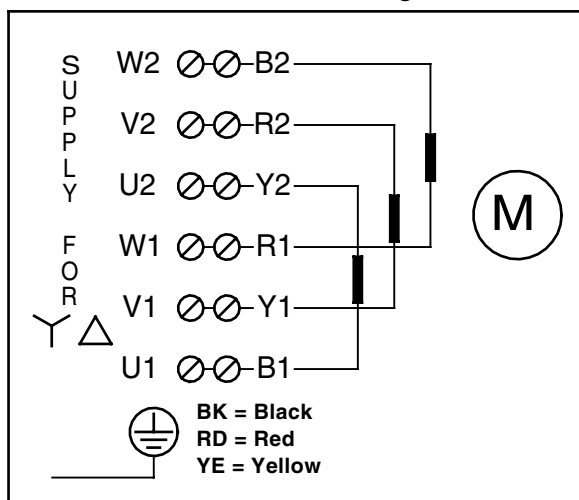

TM00 4034 3197

6.1 Frequency converter operation

Grundfos motors:

Three-phase Grundfos MS motors can be connected to a frequency converter.

If a frequency converter is to be used for booster modules connected in series, it must be connected to the last module in the flow direction.

Note: If a Grundfos MS motor with a temperature transmitter is connected to a frequency converter, a fuse incorporated in the transmitter will melt and the transmitter will be inactive. The transmitter cannot be reactivated. This means that the motor will operate like a motor without a temperature transmitter.

During frequency converter operation, it is not advisable to run the motor at a frequency higher than the nominal frequency (50 or 60 Hz). In connection with pump operation, it is important never to reduce the frequency (and consequently the speed) to such a level that the necessary flow of cooling liquid past the motor is no longer ensured.

The permissible frequency ranges are 30-50 Hz and 30-60 Hz, respectively.

During start, the maximum acceleration time from 0 to 30 Hz is 1 second.

During stop, the maximum deceleration time from 30 to 0 Hz is 1 second.

Depending on the frequency converter type, it may expose the motor to detrimental voltage peaks.

The above disturbance can be abated by installing an RC filter between the frequency converter and the motor.

Possible increased acoustic noise from the motor can be abated by installing an LC filter which will also eliminate voltage peaks from the frequency converter.

For further details, please contact your frequency converter supplier or Grundfos.



7. Motor protection

The booster module must be connected to an effective motor starter which must protect the motor against damage from voltage drop, phase failure, overload and a locked rotor.

In electricity supply systems where undervoltage and variations in phase symmetry may occur, a phase failure relay should also be fitted, see section 14. *Checking of motor and cable.*

The control circuit must always be made in such a way that all modules are stopped if one module fails.

7.1 Setting of motor starter

For cold motors, the tripping time for the motor starter must be less than 10 seconds (Class 10) at 5 times the rated full-load current ($I_{1/1}/I_{SFA}$) of the module, see the module nameplate.

Note: If this requirement is not met, the motor warranty will be invalidated.

In order to ensure the optimum protection of the submersible motor, the starter overload unit should be set in accordance with the following guidelines:

1. Set the starter overload to the rated full-load current ($I_{1/1}/I_{SFA}$) of the module.
2. Start the module and let it run for half an hour at normal performance, see section 8. *Before starting the booster module(s).*
3. Slowly grade down the scale indicator until the motor trip point is reached.
4. Increase the overload setting by 5%.

The highest permissible setting is the rated full-load current ($I_{1/1}/I_{SFA}$) of the module.

For modules wound for star-delta starting, the starter overload unit should be set as above, but the maximum setting should be as follows:

Starter overload setting = Rated full-load current x 0.58.

The highest permissible start-up time for star-delta starting is 2 seconds.

8. Before starting the booster module(s)

The booster module(s) must be filled with water before start-up.

Procedure:

1. Slacken the vent valve of the booster module, if any.
2. Ensure an inlet pressure on the booster module.
3. Completely open the isolating valve.
4. Wait 3 to 5 minutes to ensure optimum venting.
5. Tighten the vent valve.

Checking the direction of rotation:

Procedure:

1. Close the isolating valve on the discharge side of module 1 (figs. 5 to 8) to approx. 1/3 of maximum flow.
2. Start module 1 and record discharge pressure and flow readings.
3. Stop the module and interchange two of the phases to the module.
4. Restart the module and re-record discharge pressure and flow readings.
5. Stop the module.
6. Compare the results taken under points 2 and 4. The connection which gave the larger pressure and flow is the correct direction of rotation.

The check for the direction of rotation should last for the shortest possible time.

If the booster system has several modules, starting and rotation checks are made in the order 1-2-3-4 until all modules are running. When module 2 is checked, module 1 must be running. When module 3 is checked, modules 1 and 2 must be running, etc.

If modules in series are also connected in parallel (fig. 7), the direction of rotation of each section connected in series should be checked.

After having checked the direction of rotation, stop the modules in the order 4-3-2-1.

The booster system is now ready for operation.

9. Operation

Start:

The booster modules are not allowed to run against a closed discharge valve for more than 5 seconds as this will cause an increase in temperature/formation of steam in the module which may cause damage to the pump and the motor.



If there is any danger of the modules running against a closed discharge valve, a minimum liquid flow through the module should be ensured by connecting a bypass/a drain to the discharge side of the module. The drain can for instance be connected to a tank.

The booster modules must be started in the order 1-2-3-4 at intervals of 1 or 2 seconds, see section 4.1 *Booster modules connected in series and in parallel*. If other intervals are required, contact Grundfos.

Module 1 is always the first module on the suction side.

During start-up, it is recommended to close the isolating valve ¾ and open it slowly (2 to 3 seconds).

In systems involving the risk of water hammer in connection with start/stop, the necessary measures must be taken to reduce this risk, e.g. by installing a diaphragm tank.

Operation:

During operation, the inlet pressure must be checked in accordance with section 9.1 *Limitations to operation*.

The total pressure and flow of modules connected in series should never be changed by stopping one or more of the modules. If different pressures or flows are required, the following procedures are applicable:

1. Bypass of module(s): Install a bypass between two modules, see fig. 8.
Stop the module(s) which is/are not required and close the isolating valves on either side of the module.
See section 9.1.2 *Flushing of the booster module*.
The module(s) to be bypassed is/are always the last module(s) in the flow direction.
2. Fit a reducing valve to the discharge pipe.
The values stated in section 9.1 *Limitations to operation* must be observed.
3. Modules with three-phase motors: Install a frequency converter for speed control of the last booster module in the flow direction, see section 6.1 *Frequency converter operation*.

Stop:

The modules must be stopped in reverse order, i.e. 4-3-2-1, at intervals of 1 to 2 seconds, see section 4.1 *Booster modules connected in series and in parallel*.

If the booster system is taken out of operation for a long period, the modules should be flushed through with clean freshwater, see section 9.1.2 *Flushing of the booster module*. The modules are then left with freshwater until they are to be used again.

9.1 Limitations to operation

The flow limits stated in the following table apply to the optimum operating ranges of the modules as regards efficiency:

Type	Recommended flows at 25°C (77°F)			
	m³/h		US GPM	
	50 Hz	60 Hz	50 Hz	60 Hz
BM 3A/BMB 3A	0.8-4.4	1.0-5.4	3.5-17.6	4.4-23.8
BM 5A/BMB 5A	2.5-6.8	3.0-8.4	11-30	13-37
BM 8A/BMB 8A	4.0-10	4.8-10	17.6-40	21-40
BM 17/BMB 17	8.0-24	8.0-29	35-106	35-128
BM 30/BMB 30	15-38	18-45	66-167	79-198
BM 46/BMB 46	24-60	28-72	106-264	123-317
BM 60/BMB 60	35-75	40-90	154-330	176-396
BM 77/BMB 77	40-100	48-120	176-440	211-528
BM 95/BMB 95	50-120	60-140	220-528	264-616
BM 125/BMB 125	70-160	80-180	308-704	352-792

The relative pressure limits stated in the following table must be observed:

Size	Permissible relative pressures ¹⁾					
	Inlet pressure			Outlet pressure		
	Min.		Max. ²⁾		Max. ²⁾	
	[bar]	[p.s.i.]	[bar]	[p.s.i.]	[bar]	[p.s.i.]
BM 4"	0.5	7.25	60	870	80	1160
BM 6"	0.5	7.25	50	725	80	1160
BM 8"	1	14.5	25	362	70	1015
BMB 4"	0,5	7.25	30	435	60	870
BMB 6"	0,5	7.25	20	290	50	725
BMB 8"	1	14.5	10	145	45	653

1) Contact Grundfos if higher pressures are required.

2) **Note:** If the maximum inlet/outlet pressure is exceeded, install a safety valve.

9.1.1 Cooling

The temperature and flow limits stated in the following table must be observed to ensure sufficient cooling of the motor:

Motor	Maximum permissible liquid temperature			
	Maximum liquid temperature		Minimum flow velocity past the motor	
	°C	°F	m/s (ft/s)	m³/h (US GPM)
Grundfos 4"	40	104	≥ 0.15 (0.49)	≥ 0.8 (3.5)
Grundfos 6"	40	104	≥ 0.15 (0.49)	≥ 5.5 (24)
FRANKLIN 8"	30	86	≥ 0.16 (0.52)	≥ 18.5 (81.5)

9.1.2 Flushing of the booster module

When a module is flushed, the flow must be reduced to maximum 10% of the nominal flow at a minimum pressure of 2 bar. The modules must be stopped while the system is flushed, see section 9. *Operation*.

Note: When pumping water with a salt concentration > 2000 ppm NaCl, the module must be flushed through in the flow direction as described below.

The flushing procedure depends on the operating condition:

- **Intermittent operation:**
If the module has to be stopped for more than 30 minutes, it must be flushed through with clean freshwater.
- **Continuous operation:**
Once every 24 hours, the module should be stopped and flushed through with raw water by means of the feed pump.

9.1.3 Frequency of starts and stops

Minimum 1 per year is recommended.

Maximum 20 per hour.

Maximum 100 per day.

Note: BM/BMB 8": Maximum 10 per day.

10. Automatic monitoring devices

To protect the modules against dry running and to ensure a minimum flow of cooling water past the motors, the system must be fitted with flow and pressure monitoring devices (figs. 5 to 8).

A pressure switch on the suction side is dimensioned in accordance with the estimated inlet pressure. At a pressure lower than 0.5 bar for BM 4", BM 6", BMB 4" and BMB 6" and 1 bar for BM 8" and BMB 8", an alarm is given and the module must be stopped without delay.

All discharge connections to the system should be fitted with flow switches which will stop the system at the set minimum flows.

The above monitoring devices ensure a correct inlet pressure and a minimum flow of cooling water past the motor.

If the modules are stopped automatically, automatic flushing is recommended, see section 9.1.2 *Flushing of the booster module*.

11. Checking of operation

Depending on the number of operating hours of the modules, the following should be checked at suitable intervals:

- Flow.
- Starting frequency.
- Control and protective devices.
- Liquid temperature.
- Minimum flow through modules during operation.

If any of the above checks reveal any abnormal operating details, inspection should be carried out in accordance with the fault finding chart.

It is recommended to use the log book at the end of these instructions.

12. Fault finding chart



Before removing the terminal box cover and before any removal/dismantling of the module, make sure that the electricity supply has been switched off and that it cannot be accidentally switched on.



Fault	Cause	Remedy
1. The booster system stops occasionally. One or more modules stop.	a) No or insufficient water supply. The pressure switch has cut out.	Check that the pressure switch functions normally (without delay) and is adjusted correctly. Check that the minimum inlet pressure is correct.
	b) The capacity is too small. The flow switch has cut out.	The discharge pipe is totally or partly blocked due to incorrectly adjusted manually operated valve, or failure in the magnetic or motor-operated valve. Check these valves. The flow switch is faulty or incorrectly adjusted. Check/adjust the switch.
2. The booster system does not run.	a) The fuses are blown.	Check and replace both main fuses and/or fuses for control circuit.
	b) The motor starter overload unit has tripped out.	Reset the starter overload. If it trips out again, the voltage should be checked.
	c) The magnetic coil of motor starter/contactors is short-circuited (not cutting in).	Replace the coil. Check the coil voltage.
	d) The control circuit has cut out or is defective.	Check the control circuit and the contacts in the monitoring devices (pressure switch, flow switch, etc.).
	e) The motor/supply cable is defective.	Check motor and cable. See also section 14. <i>Checking of motor and cable.</i>
3. The booster system runs, but gives no water or develops no pressure.	a) No water or too small quantity delivered to the modules or air in the system.	Check that the inlet pressure during operation is at least 0.5 bar for BM 4", BM 6", BMB 4" and BMB 6" and 1 bar for BM 8" and BMB 8". If so, the water supply is OK. Stop and vent the system. Restart the system as described in section 9. <i>Operation.</i> If the module is defective, it should be dismantled and repaired/replaced.
	b) Suction parts are blocked.	Pull the pump out of the sleeve and clean the suction parts.
4. The booster system runs at reduced capacity (flow and pressure).	a) Wrong direction of rotation.	See section 8. <i>Before starting the booster module(s).</i>
	b) The valves on the discharge side are partly closed or blocked.	Check valves.
	c) The discharge pipe is partly blocked by impurities.	Measure the discharge pressure and compare with the calculated data. Clean or replace the discharge pipe.
	d) The module is partly blocked by impurities.	Pull the pump out of the sleeve. Dismantle, clean and check the pump. Any defective parts should be replaced. Clean the pipes.
	e) The module is defective.	Pull the pump out of the sleeve. Dismantle, clean and check the pump. Any defective parts should be replaced. See section 13. <i>Manuals.</i>

13. Manuals

For the replacement and repair of parts of the booster system, please refer to:

Related documentation

Service Manual for Replacement of Motor Cable and Motor (4", 6" and 8").

Parts Lists with instructions for dismantling and assembly of pump and motor.

www.grundfos.com/xxx

14. Checking of motor and cable

1. Supply voltage

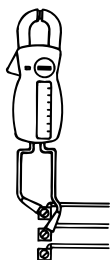

Voltmeter

TM00 1371 5092

Measure the voltage between the phases by means of a voltmeter. Connect the voltmeter to the terminals in the motor starter.

The voltage should, **when the motor is loaded**, be within $-10\%/+6\%$ of the rated voltage. The motor may burn if there are larger variations in voltage. If the voltage is constantly too high or too low, the motor must be replaced by one corresponding to the supply voltage. Large variations in voltage indicate poor electricity supply, and the module should be stopped until the defect has been found. Resetting of the motor starter may be necessary.



2. Current consumption

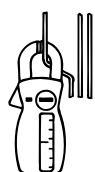

Ammeter

TM00 1372 5092

Measure the current of each phase while the module is operating at a constant discharge pressure (if possible at the capacity where the motor is most heavily loaded). For normal operating current, see nameplate.

Calculate the current unbalance (%) in the three phases as follows:

1. Add up the three phase currents.
2. Divide this value by three to ascertain the average current.
3. Find the phase current differing most from the average current.
4. Compare the results from points 2 and 3.
5. Divide the difference by the average value and multiply by 100. The result is the current unbalance in %.

For three-phase motors, the current unbalance must not exceed 5%. If so, or if the current exceeds the maximum operating current, there are the following possible faults:

- The contacts of the motor starter are burnt. Replace the contacts.
- Poor connection in leads, possibly in terminal box.
- Too high or too low supply voltage, see point 1.
- The motor windings are short-circuited or partly disjointed, see point 3.
- Damaged pump is causing the motor to be overloaded. Pull the pump out of the sleeve for overhaul.
- The resistance value of the motor windings deviates too much. Move the phases in phase order to a more uniform load. If this does not help, see point 3.

Items 3 and 4: Measurement not needed if supply voltage and current consumption are normal.

3. Winding resistance

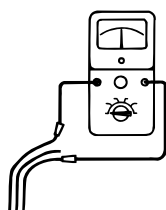

Ohmmeter

TM00 1373 5092

Remove the phase leads from the terminal box. Measure the winding resistance as shown on the drawing.

The highest value must not exceed the lowest value by more than 10%. If the deviation is higher, the pump should be pulled out. Measure motor and cable separately and replace or repair defective parts. See section 13. *Manuals*.

4. Insulation resistance

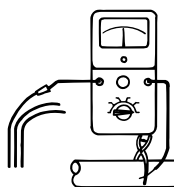

Megohmmeter

TM00 1374 5092

Remove the phase leads from the terminal box. Measure the insulation resistance from each phase to earth (frame). (Make sure that the earth connection is made carefully.)

If the measured insulation resistance is less than 0.5 megohms and the supply cable is OK, the pump should be pulled out for motor or cable repair or replacement. See section 13. *Manuals*.

15. Disposal

Disposal of this product or parts of it must be carried out according to the following guidelines:

1. Use the local public or private waste collection service.
2. In case such waste collection service does not exist or cannot handle the materials used in the product, please deliver the product or any hazardous materials from it to your nearest Grundfos company or service workshop.

Subject to alterations.

System sketch

Denmark

GRUNDFOS DK A/S
Poul Due Jensens Vej 7A
DK-8850 Bjerringbro
Tlf.: +45-87 50 50 50
Telefax: +45-87 50 51 51
E-mail: info_GDK@grundfos.com
www.grundfos.com/DK

Argentina

Bombas GRUNDFOS de Argentina S.A.
Ruta Panamericana km. 37.500 Lote 34A
1619 - Garin
Pcia. de Buenos Aires
Phone: +54-3327 414 444
Telefax: +54-3327 411 111

Australia

GRUNDFOS Pumps Pty. Ltd.
P.O. Box 2040
Regency Park
South Australia 5942
Phone: +61-8-8461-4611
Telefax: +61-8-8340 0155

Austria

GRUNDFOS Pumpen Vertrieb Ges.m.b.H.
Grundfosstraße 2
A-5082 Grödig/Salzburg
Tel.: +43-6246-883-0
Telefax: +43-6246-883-30

Belgium

N.V. GRUNDFOS Bellux S.A.
Boomsesteenweg 81-83
B-2630 Aartselaar
Tél.: +32-3-870 7300
Télécopie: +32-3-870 7301

Brazil

GRUNDFOS do Brasil Ltda.
Rua Tomazina 106
CEP 83325 - 040
Pinhais - PR
Phone: +55-41 668 3555
Telefax: +55-41 668 3554

Canada

GRUNDFOS Canada Inc.
2941 Brighton Road
Oakville, Ontario
L6H 6C9
Phone: +1-905 829 9533
Telefax: +1-905 829 9512

China

GRUNDFOS Pumps (Shanghai) Co. Ltd.
22 Floor, Xin Hua Lian Building
755-775 Huai Hai Rd, (M)
Shanghai 200020
PRC
Phone: +86-512-67 61 11 80
Telefax: +86-512-67 61 81 67

Czech Republic

GRUNDFOS s.r.o.
Cajkovského 21
779 00 Olomouc
Phone: +420-585-716 111
Telefax: +420-585-438 906

Finland

OY GRUNDFOS Pumput AB
Mestarintie 11
Piispankylä
FIN-01730 Vantaa (Helsinki)
Phone: +358-9 878 9150
Telefax: +358-9 878 91550

France

Pompes GRUNDFOS Distribution S.A.
Parc d'Activités de Chesnes
57, rue de Malacombe
F-38290 St. Quentin Fallavier (Lyon)
Tél.: +33-4 74 82 15 15
Télécopie: +33-4 74 94 10 51

Germany

GRUNDFOS GMBH
Schlüterstr. 33
40699 Erkrath
Tel.: +49-(0) 211 929 69-0
Telefax: +49-(0) 211 929 69-3799
e-mail: infoservice@grundfos.de
Service in Deutschland:
e-mail: kundendienst@grundfos.de

Greece

GRUNDFOS Hellas A.E.B.E.
20th km. Athinon-Markopoulou Av.
P.O. Box 71
GR-19002 Peania
Phone: +0030-210-66 83 400
Telefax: +0030-210-66 46 273

Hong Kong

GRUNDFOS Pumps (Hong Kong) Ltd.
Unit 1, Ground floor
Siu Wai Industrial Centre
29-33 Wing Hong Street &
68 King Lam Street, Cheung Sha Wan
Kowloon
Phone: +852-27861706/27861741
Telefax: +852-27858664

Hungary

GRUNDFOS Hungária Kft.
Park u. 8
H-2045 Törökbálint,
Phone: +36-23 511 110
Telefax: +36-23 511 111

India

GRUNDFOS Pumps India Private Limited
Flat A, Ground Floor
61/62 Chamiers Aptmt
Chamiers Road
Chennai 600 028
Phone: +91-44 432 3487
Telefax: +91-44 432 3489

Indonesia

PT GRUNDFOS Pompa
Jl. Rawa Sumur III, Blok III/CC-1
Kawasan Industri, Pulogadung
Jakarta 13930
Phone: +62-21-460 6909
Telefax: +62-21-460 6910/460 6901

Ireland

GRUNDFOS (Ireland) Ltd.
Unit 34, Stillorgan Industrial Park
Blackrock
County Dublin
Phone: +353-1-2954926
Telefax: +353-1-2954739

Italy

GRUNDFOS Pompe Italia S.r.l.
Via Gran Sasso 4
I-20060 Truccazzano (Milano)
Tel.: +39-02-95838112
Telefax: +39-02-95309290/95838461

Japan

GRUNDFOS Pumps K.K.
1-2-3, Shin Miyakoda
Hamamatsu City
Shizuoka pref. 431-21
Phone: +81-53-428 4760
Telefax: +81-53-484 1014

Korea

GRUNDFOS Pumps Korea Ltd.
6th Floor, Aju Building 679-5
Yeoksam-dong, Kangnam-ku, 135-916
Seoul Korea
Phone: +82-2-5317 600
Telefax: +82-2-5633 725

Malaysia

GRUNDFOS Pumps Sdn. Bhd.
7 Jalan Peguam U1/25
Glenmarie Industrial Park
40150 Shah Alam
Selangor
Phone: +60-3-5569 2922
Telefax: +60-3-5569 2866

Mexico

Bombas GRUNDFOS de Mexico S.A. de C.V.
Boulevard TLC No. 15
Parque Industrial Stiva Aeropuerto
Apodaca, N.L. 66600
Mexico
Phone: +52-81-8144 4000
Telefax: +52-81-8144 4010

Netherlands

GRUNDFOS Nederland B.V.
Postbus 104
NL-1380 AC Weesp
Tel.: +31-294-492 211
Telefax: +31-294-492244/492299

New Zealand

GRUNDFOS Pumps NZ Ltd.
17 Beatrice Tinsley Crescent
North Harbour Industrial Estate
Albany, Auckland
Phone: +64-9-415 3240
Telefax: +64-9-415 3250

Norway

GRUNDFOS Pumper A/S
Strømsveien 344
Postboks 235, Leirdal
N-1011 Oslo
Tlf.: +47-22 90 47 00
Telefax: +47-22 32 21 50

Poland

GRUNDFOS Pompy Sp. z o.o.
ul. Klonowa 23
Baranowo k. Poznania
PL-62-081 Przemierowo
Phone: +48-61-650 13 00
Telefax: +48-61-650 13 50

Portugal

Bombas GRUNDFOS Portugal, S.A.
Rua Calvet de Magalhães, 241
Apartado 1079
P-2770-153 Paço de Arcos
Tel.: +351-21-440 76 00
Telefax: +351-21-440 76 90

Russia

OOO GRUNDFOS
Shkolnaya 39
RUS-109544 Moscow
Phone: +7-095 564 88 00, +7-095 737 30 00
Telefax: +7-095 564 88 11, +7-095 737 75 36
e-mail: grundfos.moscow@grundfos.com

Singapore

GRUNDFOS (Singapore) Pte. Ltd.
24 Tuas West Road
Jurong Town
Singapore 638381
Phone: +65-6865 1222
Telefax: +65-6861 8402

Spain

Bombas GRUNDFOS España S.A.
Camino de la Fuentequilla, s/n
E-28110 Algete (Madrid)
Tel.: +34-91-848 8800
Telefax: +34-91-628 0465

Sweden

GRUNDFOS AB
Box 63, Angeredsvinkeln 9
S-424 22 Angered
Tel.: +46-771-32 23 00
Telefax: +46-31 331 94 60

Switzerland

GRUNDFOS Pumpen AG
Bruggacherstrasse 10
CH-8117 Fällanden/ZH
Tel.: +41-1-806 8111
Telefax: +41-1-806 8115

Taiwan

GRUNDFOS Pumps (Taiwan) Ltd.
14, Min-Yu Road
Tunglo Industrial Park
Tunglo, Miao-Li County
Taiwan, R.O.C.
Phone: +886-37-98 05 57
Telefax: +886-37-98 05 70

Thailand

GRUNDFOS (Thailand) Ltd.
947/168 Moo 12, Bangna-Trad Rd., K.M. 3,
Bangna, Phrakonong
Bangkok 10260
Phone: +66-2-744 1785 ... 91
Telefax: +66-2-744 1775 ... 6

Turkey

GRUNDFOS POMPA SAN. ve TIC. LTD. STI
Bulgurlu Caddesi no. 32
TR-81190 Üsküdar Istanbul
Phone: +90 - 216-4280 306
Telefax: +90 - 216-3279 988

United Arab Emirates

GRUNDFOS Gulf Distribution
P.O. Box 16768
Jebel Ali Free Zone
Dubai
Phone: +971-4- 8815 166
Telefax: +971-4-8815 136

United Kingdom

GRUNDFOS Pumps Ltd.
Grovebury Road
Leighton Buzzard/Beds. LU7 8TL
Phone: +44-1525-850000
Telefax: +44-1525-850011

U.S.A.

GRUNDFOS Pumps Corporation
17100 West 118th Terrace
Olathe, Kansas 66061
Phone: +1-913-227-3400
Telefax: +1-913-227-3500

CALL 1-800-577-8111 FOR SALES AND SUPPORT

150095 0804	30
Repl. 150095 0503	