

Contents

Mission

Product data

| | |
|----------------------------|---|
| Performance range | 4 |
| Product range | 5 |
| Applications | 5 |
| Pump | 6 |
| Motor | 6 |
| Terminal box positions | 6 |
| Sectional drawing | 7 |
| Materials | 7 |
| Type key | 7 |
| Operating conditions | 8 |
| Maximum inlet pressure | 8 |
| Maximum operating pressure | 8 |
| Pumped liquids | 8 |

Selection and sizing

| | |
|----------------------------------|----|
| Selection of pumps | 9 |
| How to read the curve charts | 13 |
| Guidelines to performance curves | 13 |

Performance curves

Technical data

| | |
|-----------|----|
| CRT(E) 2 | 14 |
| CRT(E) 4 | 16 |
| CRT(E) 8 | 18 |
| CRT(E) 16 | 20 |

Motor data

| | |
|---------------------------------------|----|
| Grundfos specified Baldor TEFC motors | 22 |
| MLE motors | 23 |

Accessories

| | |
|---------------------|----|
| Pipework connection | 24 |
|---------------------|----|

Variants

| | |
|--------------------------------|----|
| Lists of variants - on request | 25 |
| Motors | 25 |
| Shaft seals | 25 |
| Pumps | 25 |

Further product documentation

| | |
|----------------------------------|----|
| Sources of product documentation | 26 |
| WinCAPS® | 26 |
| WebCAPS® | 27 |

Mission

- to successfully develop, produce, and sell high quality pumps and pumping systems worldwide, contributing to a better quality of life and healthier environment



GBJ - Bjerringbro, Denmark



GMU - Fresno, California



GPU - Olathe, Kansas



GMX - Monterrey, Mexico



GPA - Allentown, Pennsylvania



GCA - Oakville, Ontario

- One of the 3 largest pump companies in the world
- World headquarters in Denmark
- North American headquarters in Kansas City - Manufacturing in Fresno, California
- 60 companies in 40 countries
- More than 10 million pumps produced annually worldwide
- North American companies operating in USA, Canada and Mexico
- Continuous reinvestment in growth and development enables the company to **BE** responsible, **THINK** ahead, and **INNOVATE**

Performance range

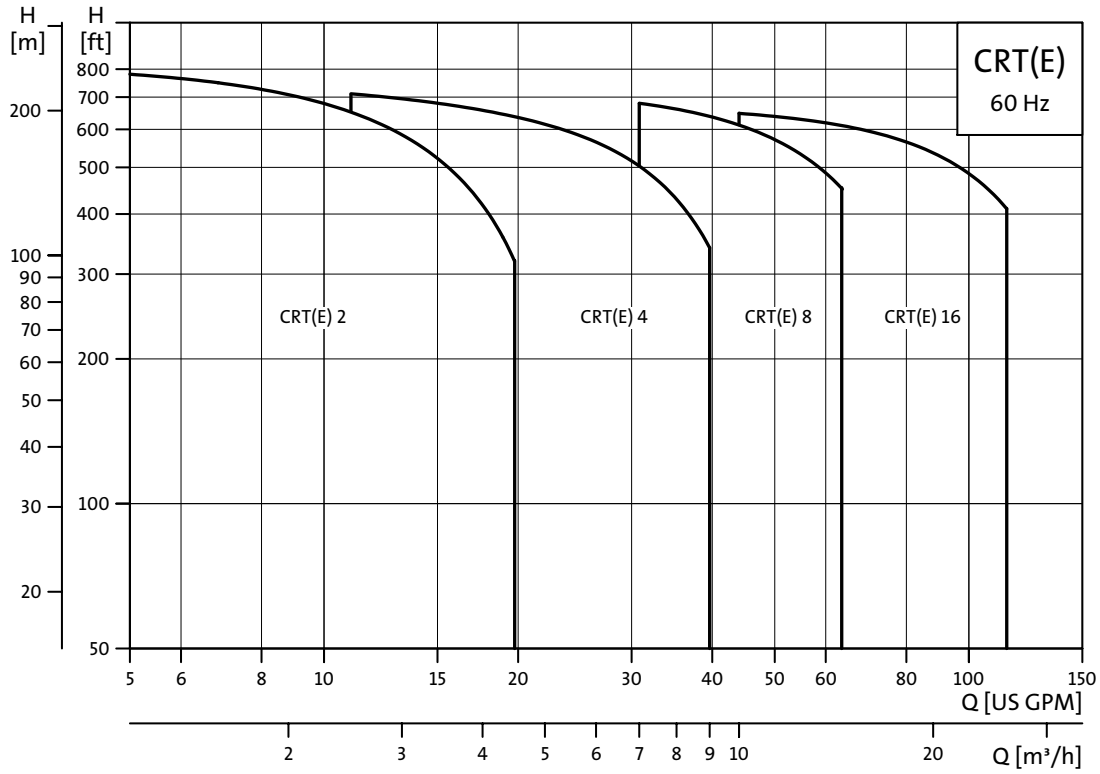

TMO2 8328 4903

Product range

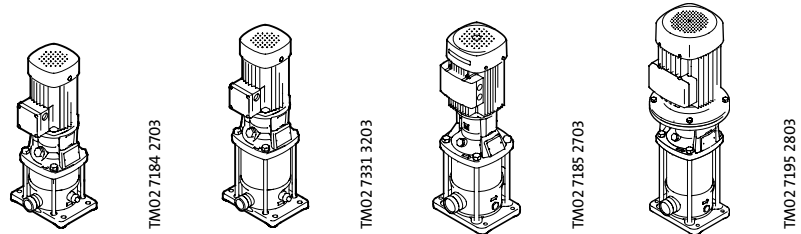

| Description | CRT(E) 2 | CRT(E) 4 | CRT(E) 8 | CRT(E) 16 |
|----------------------------------|------------|------------|------------|------------|
| Range | | | | |
| Nominal flow rate [US GPM] | 13 | 30 | 50 | 80 |
| Max. operating pressure [psi] | 362 | 362 | 362 | 362 |
| Temperature range [°F] | -4 to +248 | -4 to +248 | -4 to +248 | -4 to +248 |
| Maximum efficiency [%] | 48 | 59 | 64 | 70 |
| Flow range [US GPM] | 1.3 to 20 | 3 to 40 | 5 to 64 | 8 to 114 |
| Motor power range [Hp] | 0.5 to 5 | 0.5 to 7.5 | 0.75 to 15 | 5 to 25 |
| Pipework connection | | | | |
| PJE (victaulic type) coupling | 1.25" | 1.25" | 2" | 2" |
| ANSI flange adapter - on request | - | - | 2" | 2" |

Applications

Reliable and cost-efficient, CRT pumps handle a variety of liquids from sea water to sodium hypochlorite.

Excellent corrosion resistance

Titanium is widely used for many industrial applications due to its high resistance to corrosion.

Totally unaffected by corrosive attacks by salt water or marine atmospheres, titanium also has an exceptional resistance to a wide range of acids, alkalies, natural water and industrial chemicals.

The fine corrosion resistance of titanium is due to a stable, protective and strongly adherent oxide film, formed instantly on the metal when a fresh surface is exposed to air or moisture.

Fields of application

Marine environment

- Ballast pumps
- Washing/cleaning

Pulp and paper industries

- Bleaching solutions

Offshore industries and refineries

- Fire fighting
- Cooling

Metal-finishing industries (electroplating)

- Copper chloride etching
- Ammonium chloride etching

Power generation plants

- FGD (Flue Gas Desulphurization)

Food processing, brewing and pharmaceutical industries

- CIP (Cleaning In Place)
- Disinfection

Desalination industries

- Reverse osmosis
- Distillation

Chemical processing industries

- Chlorine and chlorates
- Organic acids
- Oxidizing acids (nitric acid, chromic acid)
- Chloride-containing salts (ferric chloride)
- Inhibited reducing acids

Other

- Fish farming
- Aquariums
- Fun water parks

Pump

The CRT and CRTE pumps are non-self-priming, vertical multistage centrifugal pumps. The pumps are available with Grundfos standard motors (CRT pumps) or frequency-controlled motors (CRTE pumps).

The pump consists of a base and a pump head. The chamber stack and the outer sleeve are secured between the pump head and the base by means of staybolts. The base has suction and discharge ports on the same level (in-line).

All pumps are equipped with a maintenance-free mechanical shaft seal.



GR7369

Fig. 1 CRT pumps

Motor

Grundfos standard motors - MG and Baldor® motors

CRT pumps are fitted with Grundfos specified motors. The motors are all heavy-duty 2-pole, NEMA frame, C-face motors.

Frequency-controlled motors - MLE motors

CRTE pumps are fitted with totally enclosed, fan-cooled, 2-pole frequency-controlled motors.

From 0.5 Hp to 1.5 Hp Grundfos offers CRTE pumps fitted with single-phase MLE motors (1 x 208-230 V).

From 1.0 Hp to 10 Hp Grundfos offers CRTE pumps fitted with three-phase MLE motors (3 x 460-480 V).

Electrical data

| | |
|-------------------------|---|
| Mounting designation | NEMA |
| Insulation class | F/B/H |
| Efficiency class | Standard efficiency Energy efficient / EPAct - on request Premium efficiency - on request |
| Enclosure class | TEFC - Totally Enclosed Fan Cooled |
| 60 Hz Standard voltages | 1 x 115/208-230 V 3 x 208-230/460 V 3 x 575 V |



Approvals



Optional motors

The Grundfos standard range of motors covers a wide variety of application demands. However, for special applications or operating conditions, custom-built motor solutions can be provided.

For special applications or operating conditions, Grundfos offers custom-built motors such as:

- Explosion proof motors,
- motors with anti-condensation heating units,
- low-noise motors,
- energy efficient and premium efficiency motors,
- motors with thermal protection.

Motor protection

Single-phase Grundfos specified motors have built-in thermal overload switches (up to 7.5 Hp).

Three-phase motors **must** be connected to motor starters in accordance with local regulations.

Single- and three-phase MLE motors have built-in thermal protection.

Terminal box positions

As standard the terminal box is mounted on the suction side of the pump.

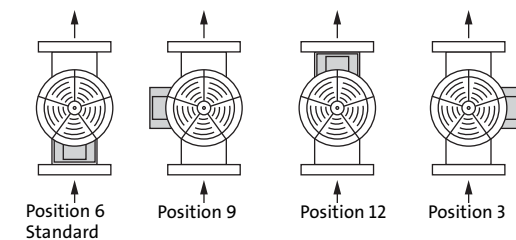

Terminal box positions

TM0218 05 2001

Sectional drawing

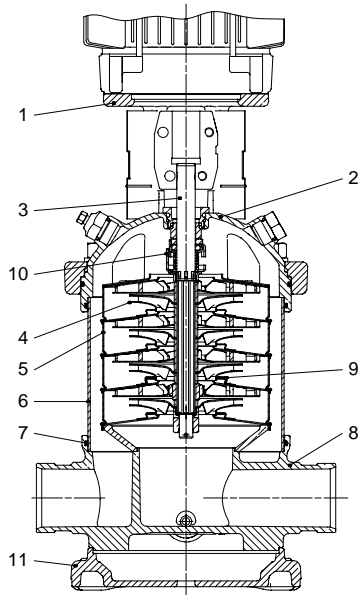

TMO2 7196 2803

Type key

| Example | CR | T | E | 16 | -3 | A | -P | -A | -E | AUUE |
|--|----|---|---|----|----|---|----|----|----|------|
| Pump range | | | | | | | | | | |
| Version with vital parts in titanium | | | | | | | | | | |
| Pump with integrated frequency control | | | | | | | | | | |
| Nominal flow rate [m ³ /h] | | | | | | | | | | |
| Number of impellers | | | | | | | | | | |
| Code for pump version | | | | | | | | | | |
| Code for pipework connection | | | | | | | | | | |
| Code for materials, excl. plastic and rubber parts (A = basic version) | | | | | | | | | | |
| Code for neck ring material | | | | | | | | | | |
| Code for shaft seal and plastic/rubber parts, excl. neck ring | | | | | | | | | | |

Materials

| Pos. | Description | Materials | EN/DIN | AISI/ASTM |
|------|-------------------------|-------------------------|--------|-------------------------|
| 1 | Pump head | Stainless steel | 1.4308 | CF 8 (eq. to AISI 304) |
| 2 | Pump head cover | Titanium (cast) | - NA - | Grade 5 |
| 3 | Shaft | Titanium | 3.7165 | Grade 5 |
| 4 | Impeller | Titanium | 3.7025 | Grade 1 |
| 5 | Intermediate chamber | Titanium | 3.7025 | Grade 1 |
| 6 | Outer sleeve | Titanium | 3.7035 | Grade 1 |
| 7 | O-ring for outer sleeve | EPDM or FKM | | |
| 8 | Base | Titanium (cast) | - NA - | Grade 5 |
| 9 | Neck ring | PTFE | | |
| 10 | Shaft seal | AUUE/AUVV ¹⁾ | | |
| 11 | Base plate | Stainless steel | 1.4408 | CF 8M (eq. to AISI 316) |
| | Rubber parts in pump | Same as in shaft seal | | |
| | Bearing rings | Silicon carbide | | |
| | Plugs | Titanium | 3.7165 | Grade 2 |
| | Staybolts | Stainless steel | | AISI 431 |
| | Strap (CRT 8/16) | Titanium | 3.7035 | Grade 2 |

- NA - : Standard not available

1) : Standard is hastelloy C-276 / Binderless tungsten carbide / EPDM or FKM.

Shaft seal with titanium metal parts, silicon carbide/silicon carbide/ E/V/K available on request.

Operating conditions

| Description | Operating conditions |
|------------------------|---|
| Liquid temperature | EPDM: -4°F to +248°F. FKM: -4°F to +194°F. |
| Ambient temperature | Maximum +104°F. |
| Minimum inlet pressure | According to the NPSH _R curve + a safety margin of minimum 2 feet. |

Maximum inlet pressure

The following table shows the maximum permissible inlet pressure. However, the actual inlet pressure + pressure against a closed valve must always be lower than the maximum permissible operating pressure.

| 60 Hz | | |
|---------------------|--|---------|
| CRT(E) 2-2 → 2-6 | | 145 psi |
| CRT(E) 2-7 → 2-18 | | 217 psi |
| CRT(E) 4-1 → 4-7 | | 145 psi |
| CRT(E) 4-8 → 4-16 | | 217 psi |
| CRT(E) 8-1 → 8-16 | | 145 psi |
| CRT(E) 16-2 → 16-12 | | 145 psi |

Maximum operating pressure

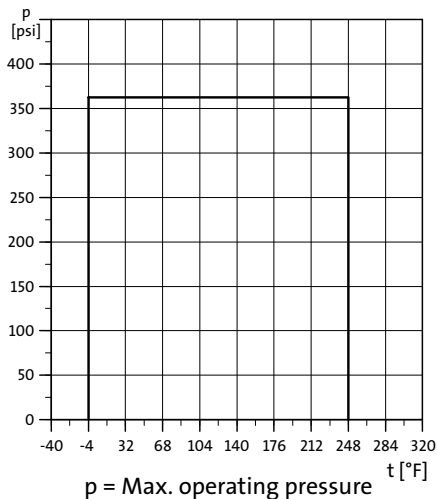

TM02 8329 0105

Fig. 2 Operating pressure and temperature limits.

Note: Liquid temperatures above 194°F may involve the risk of periodic noise from the shaft seal.

Pumped liquids

Thin, non-explosive liquids, not containing solid particles or fibers. The liquid must not attack the pump materials chemically.

When pumping liquids with a density and/or viscosity higher than that of water, motors with correspondingly higher outputs must be used, if required.

CRT pumps can be used for liquid transfer, circulation and pressure boosting.

Corrosion resistance for CRT(E)

| Media | Conc. [%] | Temp. [°F] | Seal face | | Bearing |
|--|-----------|------------|------------------------------------|------------------------|-----------------|
| | | | Binderless tungsten carbide (AUUx) | Silicon carbide (AQQx) | Silicon carbide |
| Demineralized water | | 248 | ● | | ● |
| Ground water | | 248 | ● | | ● |
| Brackish water | | 248 | ● | | ● |
| Seawater | | 176 | ● | | ● |
| Sulfuric acid | 3 | 140 | | ●●● | ● |
| Phosphoric acid | 30 | 95 | ● | | ● |
| | 10 | 140 | | | |
| Formic acid | 50 | 176 | | ●●● | ● |
| Citric acid | 50 | 212 | ● | | ● |
| Oxalic acid | 5 | 68 | ● | | ● |
| Inorganic salts (including FeCl ₃) | | | | ●●● | ● |
| Sodium hydroxide | 10 | 212 | ● | | ● |
| | 50 | 140 | | | |
| Potassium hydroxide | 50 | 68 | ● | | ● |
| Calcium hydroxide | saturated | 212 | ● | | ● |
| Ammonium hydroxide | 28 | 212 | ● | | ● |
| Alcohols (except for methanol ★), aldehydes, ketones | | | ● | | ● |

★ Titanium is susceptible to stress corrosion cracking (SSC) in methanol and should not be used with methanol.
★★ Available on request.

Selection of pumps

Selection of pumps should be based on

- The duty point of the pump (see section 1)
- **Sizing** data such as pressure loss as a result of height differences, friction loss in the pipework, pump efficiency etc. (see section 2)
- Pump materials (see section 3)
- Pump connections (see section 4)
- Shaft seal (see section 5).

1. Duty point of the pump

From a duty point it is possible to select a pump on the basis of the curve charts shown in the chapter of "Performance curves" from page 14 to 20.

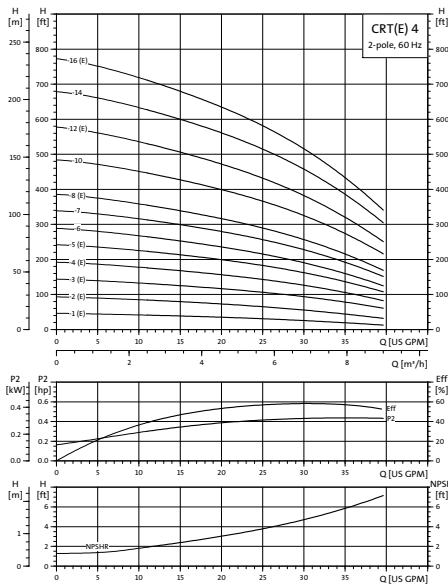

Fig. 3 Example of a curve chart

2. Sizing data

When sizing a pump the following must be taken into account (see fig. 6)

- Required flow and pressure at the point of use.
- Pressure loss as a result of height differences (H_{geo}).
- Friction loss in the pipework (H_f).
- It may be necessary to account for pressure loss in connection with long pipes, bends or valves, etc.
- Best efficiency at the estimated duty point.
- NPSH value.
- For calculation of the NPSH value, see "Minimum inlet pressure - NPSH" page 12.

Efficiency

Before determining the point of best efficiency, the operation pattern of the pump needs to be identified. If the pump is expected to operate at the **same** duty point, then select a CRT(E) pump which is operating at a duty point corresponding with the best efficiency of the pump.

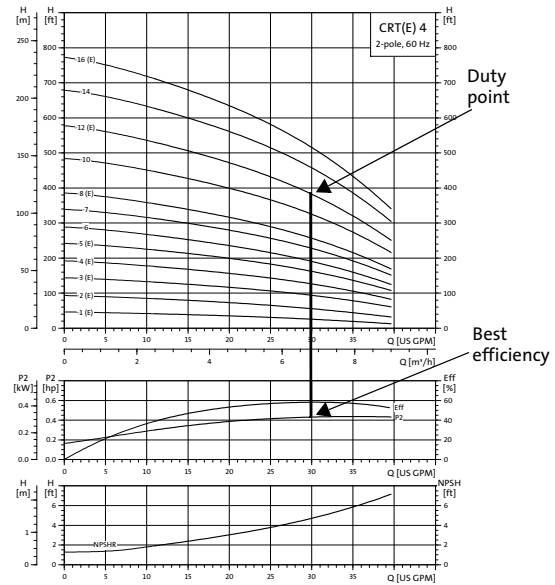

Fig. 4 Example of a CRT(E) pump's duty point

As the pump is sized on the basis of the highest possible flow, it is important to always have the duty point to the right of the optimum efficiency point (see fig.5, range with check mark). This must be considered in order to keep efficiency high when the flow drops.

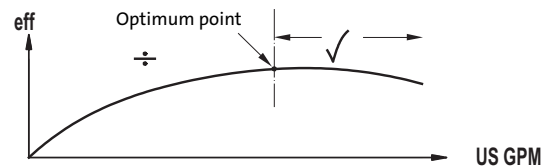

Fig. 5 Best efficiency

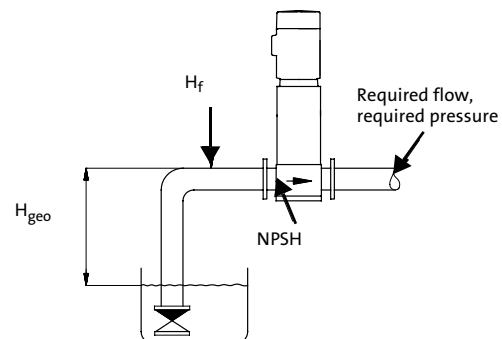

Fig. 6 Sizing data

Normally, E-pumps are used in applications characterized by a **variable** flow. Consequently, it is not possible to select a pump that is constantly operating at optimum efficiency.

In order to achieve optimum operating economy, the pump should be selected on the basis of the following criteria:

- The max. required duty point should be as close as possible to the QH curve of the pump.
- The required duty point should be positioned so that P_2 is close to the max. point of the 100% curve.

Between the min. and max. performance curve E-pumps have an infinite number of performance curves each representing a specific speed. Therefore it may not be possible to select a duty point close to the 100% curve.

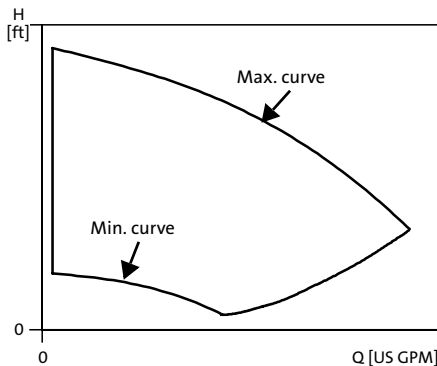

Fig. 7 Min. and max. performance curves

In situations where it is not possible to select a duty point close to the 100% curve the affinity equations to the right can be used. The head (H), the flow (Q) and the input power (P) are all the appropriate variables for the motor speed (n).

Note:

The approximated formulas apply on condition that the system characteristic remains unchanged for n_n and n_x and that it is based on the formula $H = k \times Q^2$, where k is a constant.

The power equation implies that the pump efficiency is unchanged at the two speeds. In practice this is **not** quite correct.

Finally, it is worth noting that the efficiencies of the frequency converter and the motor **must** be taken into account if a precise calculation of the power saving resulting from a reduction of the pump speed is wanted.

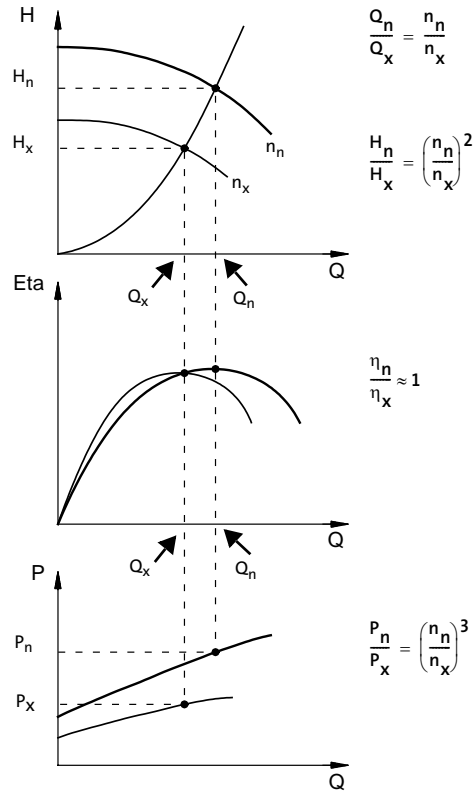

Fig. 8 Affinity equations

Legend

- H_n Rated head in feet
- H_x Current head in feet
- Q_n Rated flow in US GPM
- Q_x Current flow in US GPM
- n_n Rated motor speed in min^{-1} ($n_n = 3500 \text{ min}^{-1}$)
- n_x Current motor speed in min^{-1}
- η_n Rated efficiency in %
- η_x Current efficiency in %

WinCAPS® and WebCAPS®

WinCAPS and WebCAPS are both selection programs offered by Grundfos.

The two programs make it possible to calculate an E-pump's specific duty point and energy consumption.

By entering the sizing data of the pump, WinCAPS and WebCAPS can calculate the exact duty point and energy consumption. For further information see page 26 and page 27.

TM02 7572 4803

TM00 8720 3496

3. Material

The material variant should be selected based of the liquid to be pumped.

4. Pump connection

Selection of pump connection depends on the rated pressure and pipework. To meet any requirement the CRT(E) pumps offer the following connections:

- PJE coupling - Fig. 10
- ANSI adapter, (CRT 8 and CRT 16 only - sold separately)

5. Shaft seal

As standard, the CRT(E) range is fitted with a Grundfos type A shaft seal suitable for the most common applications, see Fig. 11.

In service situations Grundfos type A shaft seals can be replaced without dismantling the pump head.

The following three key parameters **must** be taken into account, when selecting the shaft seal:

- Type of pumped liquid
- liquid temperature and
- maximum pressure.

Inlet pressure and operating pressure

The limit values stated on page 8 must **not** be exceeded as regards ...

- maximum inlet pressure and
- maximum operating pressure.

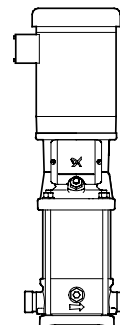

Fig. 9 CRT pump

TM02.9594.3404

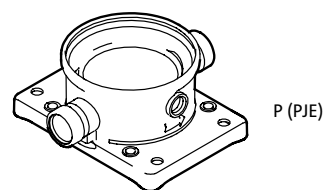

Fig. 10 Pump connections

TM02.9593.3404

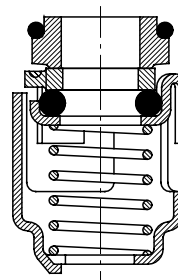

Fig. 11 Shaft seal

TM00.2581.4593

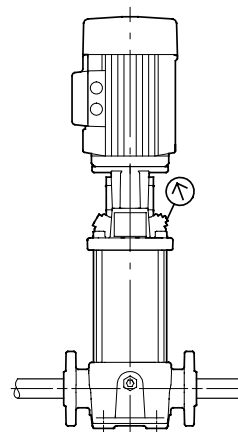

Fig. 12 Inlet and operating pressure

TM02.1204.0601

Minimum inlet pressure - NPSH

Calculation of the inlet pressure "H" is recommended when ...

- the liquid temperature is high,
- the flow is significantly higher than the rated flow,
- water is drawn from depths,
- water is drawn through long pipes,
- inlet conditions are poor.

To avoid cavitation, make sure that there is a minimum pressure on the suction side of the pump. The maximum suction lift "H" in feet can be calculated as follows:

$$H = p_b - \text{NPSH} - H_f - H_v - H_s$$

p_b = Barometric pressure in feet absolute.
(Barometric pressure can be set to 33.9 feet at sea level).
In closed systems, p_b indicates the system pressure in feet.

NPSH = Net Positive Suction Head in feet.
(To be read from the NPSH curve at the highest flow the pump will be delivering).

H_f = Friction loss in suction pipe in feet.
(At the highest flow the pump will be delivering.)

H_v = Vapor pressure in feet.
(To be read from the vapor pressure scale. " H_v " depends on the liquid temperature " T_m ").

H_s = Safety margin = minimum 2.0 feet.

If the "H" calculated is positive, the pump can operate at a suction lift of maximum "H" feet of head.

If the "H" calculated is negative, an inlet pressure of minimum "H" feet is required.

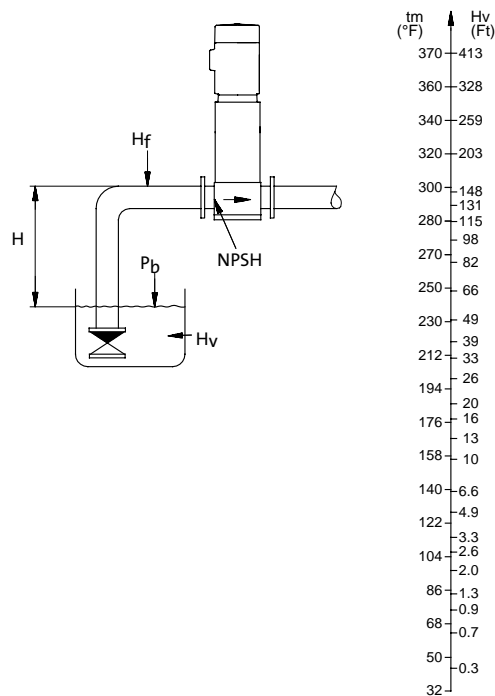

Fig. 13 Minimum inlet pressure - NPSH

Note: In order to avoid cavitation, **never** select a pump whose duty point lies too far to the right on the NPSH curve.

Always check the NPSH value of the pump at the highest possible flow.

TM02.7729.3903

How to read the curve charts

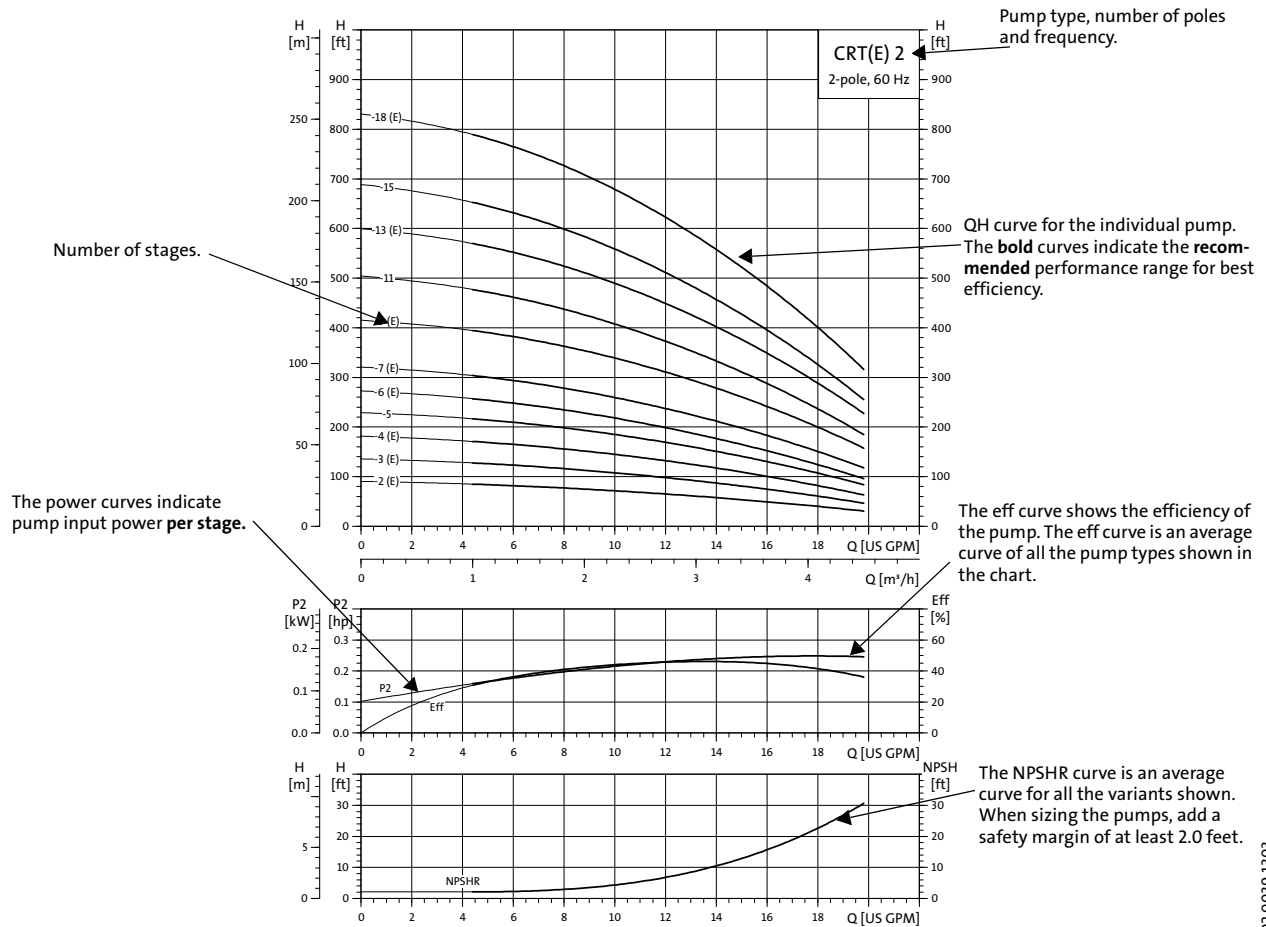

E03 6600 20M

Fig. 14 How to read the curve charts

Guidelines to performance curves

The guidelines below apply to the curves shown on the following pages:

1. The motors used for the measurements are standard motors (TEFC or MLE).
2. Measurements have been made with airless water at a temperature of 68°F.
3. The curves apply to a kinematic viscosity of $\nu = 1 \text{ mm}^2/\text{s}$ (1 cSt).
4. Due to the risk of overheating, the pumps should not be used at a flow below the minimum flow rate.
5. The QH curves apply to actual speed with the motor types mentioned at 60 Hz.

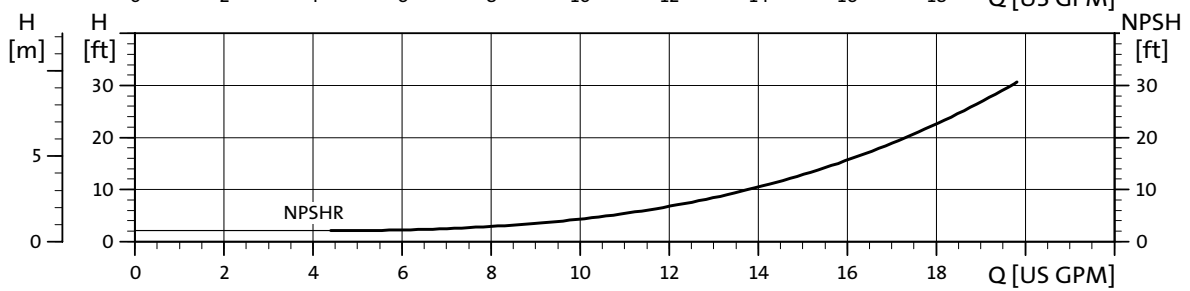
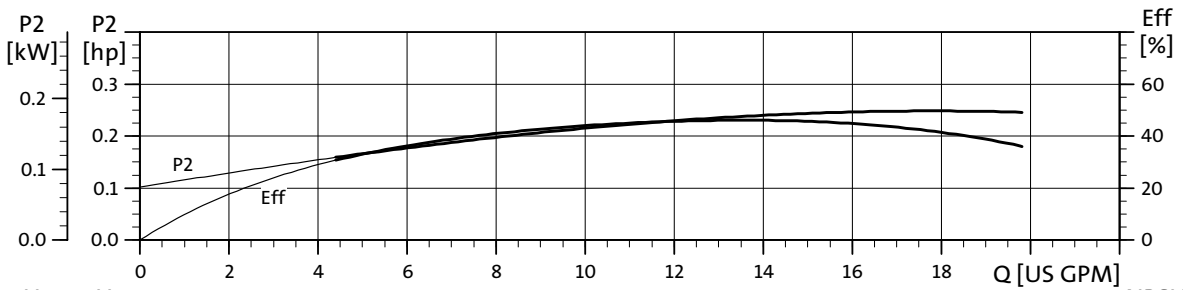
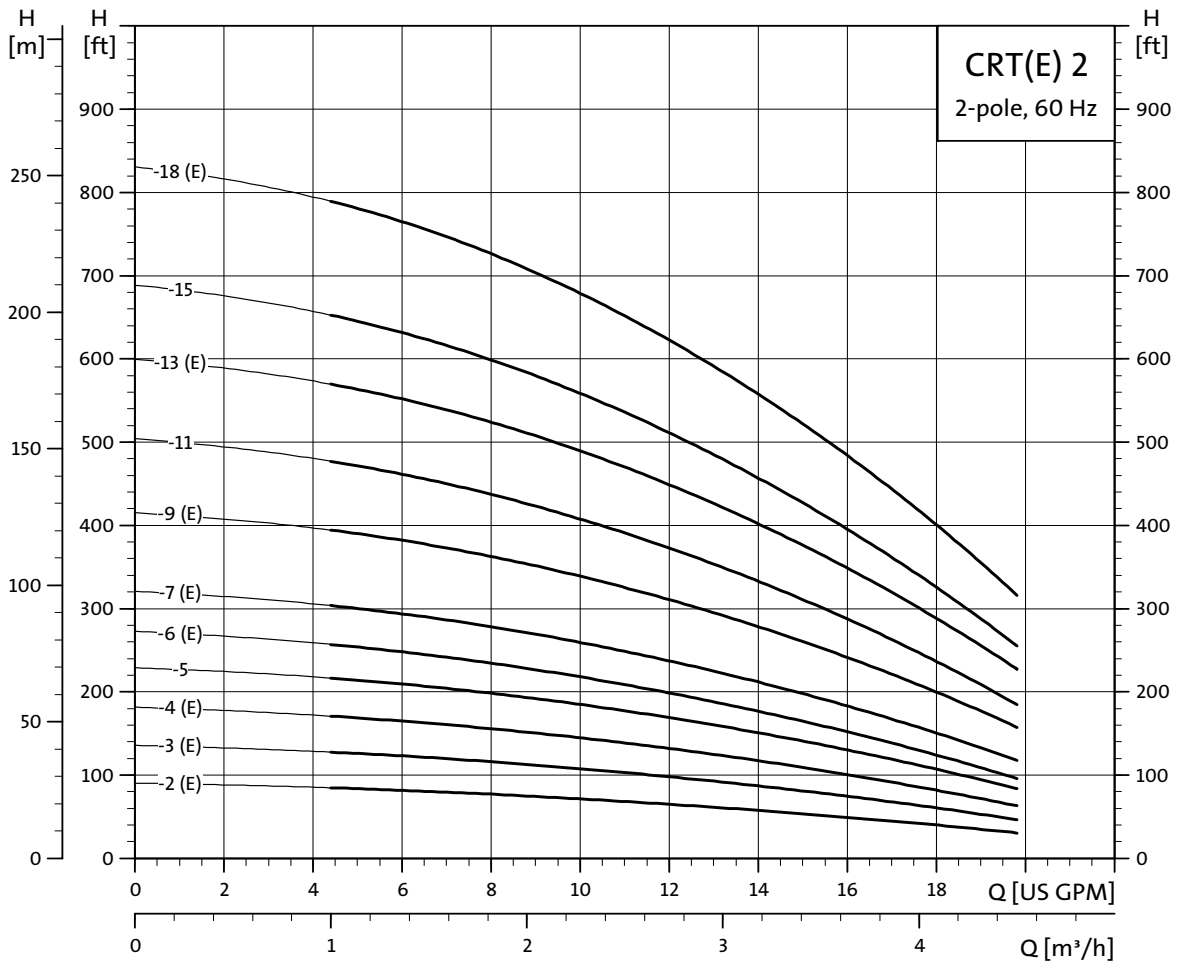

TM02 8330 0405

Dimensional sketches

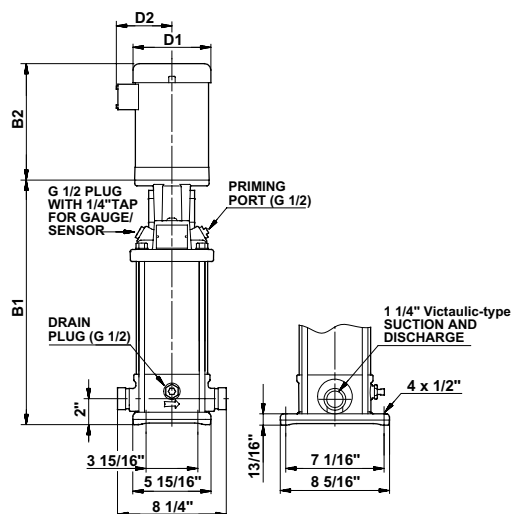

TM02 2149 4604

Dimensions and weight

| Pump Type | HP | PH | Voltage | Frame Size | CRT | | | | | CRTE | | | |
|-------------|-------|----|-------------|------------|------------|--------|-------|--------|----------|------------|-------|--------|----------|
| | | | | | Dimensions | | | | Ship Wt. | Dimensions | | | Ship Wt. |
| | | | | | B1 | D1 | D2 | B1+B2 | | D1 | D2 | B1+B2 | |
| CRT(E) 2-2 | 1/2 | 1 | 115/208-230 | 56C | 10 | 6 1/4 | 5 | 19 3/8 | 52 | 5 5/8 | 5 5/8 | 17 3/4 | 37 |
| | | 3 | 208-230/460 | 56C | 10 | 6 1/4 | 5 | 19 3/8 | 46 | - | - | - | - |
| CRT(E) 2-3 | 3/4 | 1 | 115/208-230 | 56C | 10 | 6 1/4 | 5 | 20 | 55 | 5 5/8 | 5 5/8 | 17 3/4 | 39 |
| | | 3 | 208-230/460 | 56C | 10 | 6 1/4 | 5 | 19 3/8 | 48 | - | - | - | - |
| CRT(E) 2-4 | 1 | 1 | 115/208-230 | 56C | 11 1/2 | 7 1/4 | 5 3/4 | 22 3/4 | 68 | 5 5/8 | 5 5/8 | 20 3/4 | 43 |
| | | 3 | 208-230/460 | 56C | 11 1/2 | 7 1/4 | 5 3/4 | 21 3/4 | 58 | 7 1/8 | 6 5/8 | 22 7/8 | 68 |
| CRT 2-5 | 1 1/2 | 1 | 115/208-230 | 56C | 11 1/2 | 7 1/4 | 5 3/4 | 23 1/4 | 74 | - | - | - | - |
| | | 3 | 208-230/460 | 56C | 11 1/2 | 7 1/4 | 5 3/4 | 22 1/4 | 62 | - | - | - | - |
| CRT(E) 2-6 | 1 1/2 | 1 | 115/208-230 | 56C | 12 7/8 | 7 1/4 | 5 3/4 | 24 5/8 | 76 | 5 5/8 | 5 5/8 | 22 1/8 | 49 |
| | | 3 | 208-230/460 | 56C | 12 7/8 | 7 1/4 | 5 3/4 | 23 5/8 | 63 | 7 1/8 | 6 5/8 | 24 1/4 | 69 |
| CRT(E) 2-7 | 2 | 1 | 115/208-230 | 56C | 12 7/8 | 7 1/4 | 5 3/4 | 25 1/2 | 83 | - | - | - | - |
| | | 3 | 208-230/460 | 56C | 12 7/8 | 7 1/4 | 5 3/4 | 24 5/8 | 71 | 7 1/8 | 6 5/8 | 24 1/4 | 74 |
| CRT(E) 2-9 | 3 | 1 | 115/208-230 | 182TC | 16 | 8 5/8 | 6 7/8 | 30 1/2 | 110 | - | - | - | - |
| | | 3 | 208-230/460 | 182TC | 16 | 8 5/8 | 6 7/8 | 28 1/2 | 91 | 7 1/8 | 6 5/8 | 28 7/8 | 84 |
| CRT 2-11 | 3 | 1 | 115/208-230 | 182TC | 16 | 8 5/8 | 6 7/8 | 30 1/2 | 111 | - | - | - | - |
| | | 3 | 208-230/460 | 182TC | 16 | 8 5/8 | 6 7/8 | 28 1/2 | 91 | - | - | - | - |
| CRT(E) 2-13 | 3 | 1 | 115/208-230 | 182TC | 18 3/4 | 8 5/8 | 6 7/8 | 33 1/4 | 114 | - | - | - | - |
| | | 3 | 208-230/460 | 182TC | 18 3/4 | 8 5/8 | 6 7/8 | 31 1/4 | 94 | 7 1/8 | 6 5/8 | 31 5/8 | 88 |
| CRT 2-15 | 5 | 1 | 208-230 | 182TC | 18 3/4 | 10 5/8 | 7 1/2 | 34 1/8 | 144 | - | - | - | - |
| | | 3 | 208-230/460 | 182TC | 18 3/4 | 8 5/8 | 6 | 34 3/4 | 111 | - | - | - | - |
| CRT(E) 2-18 | 5 | 1 | 208-230 | 182TC | 21 1/2 | 10 5/8 | 7 1/2 | 36 7/8 | 150 | - | - | - | - |
| | | 3 | 208-230/460 | 182TC | 21 1/2 | 8 5/8 | 6 | 37 1/2 | 117 | 8 3/4 | 7 1/2 | 36 3/8 | 123 |

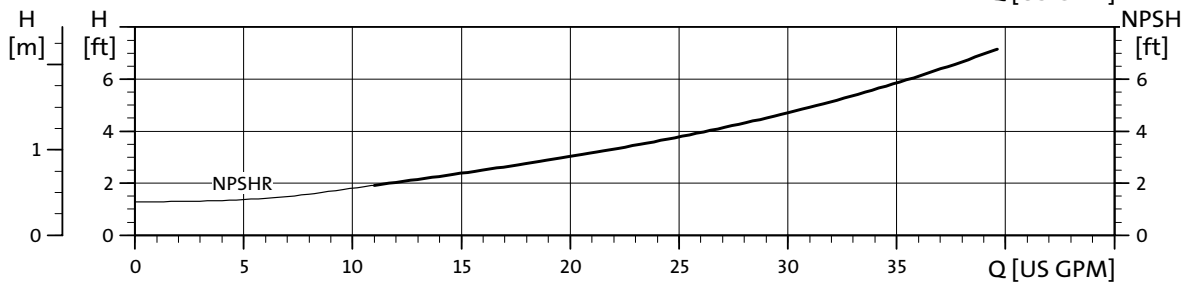
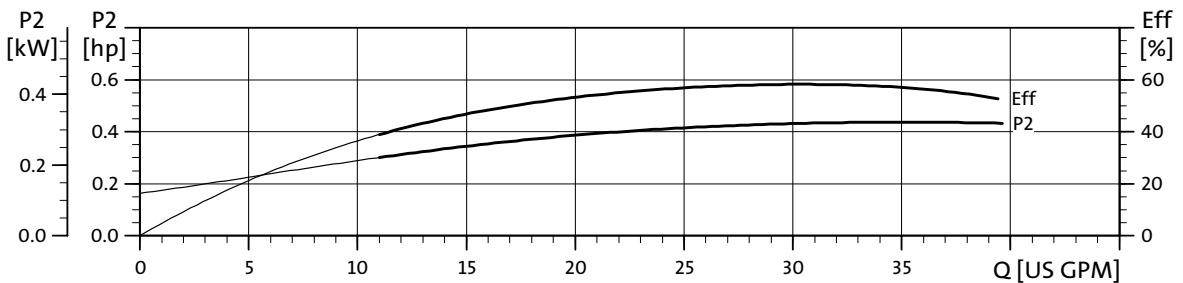
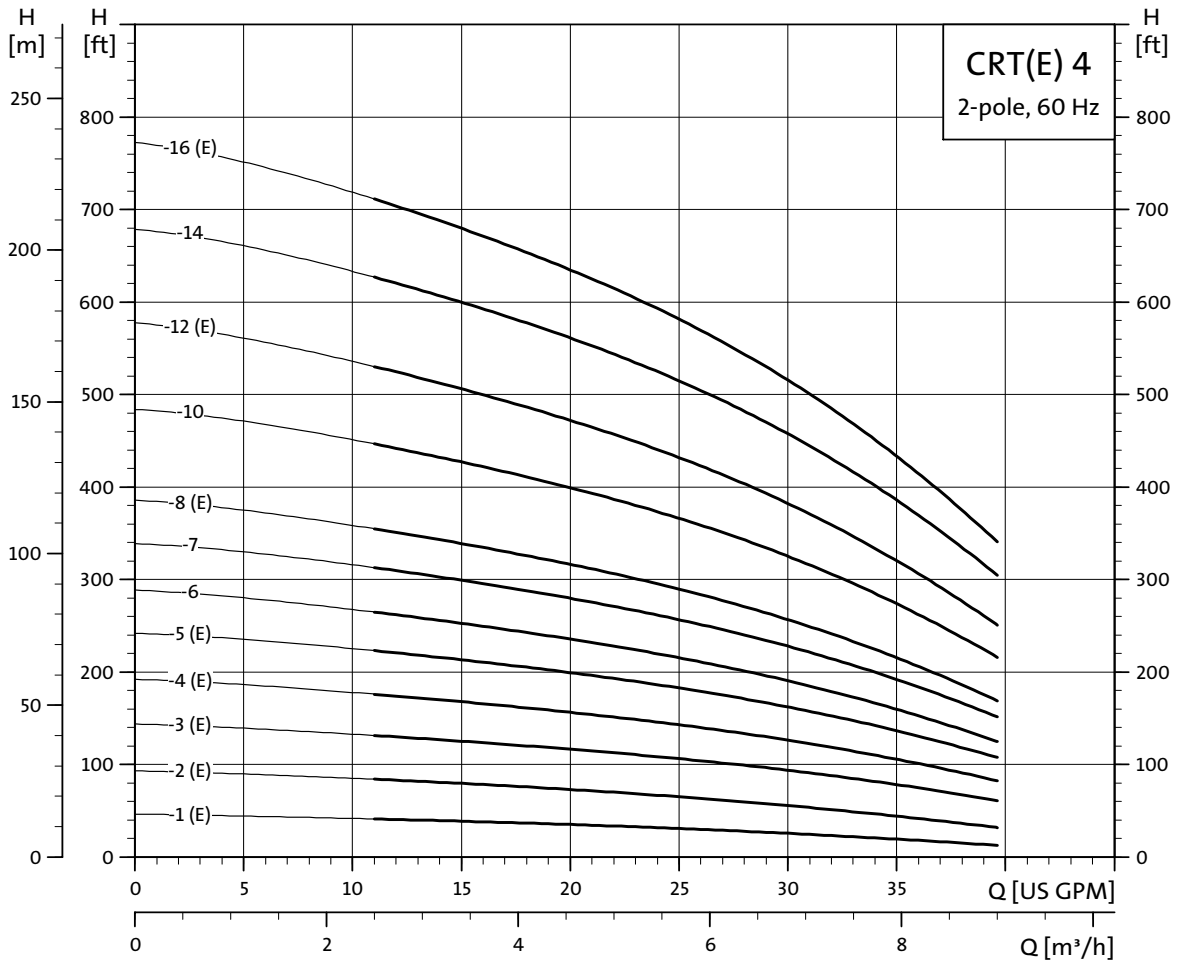

TM02 8331 0405

Dimensional sketches

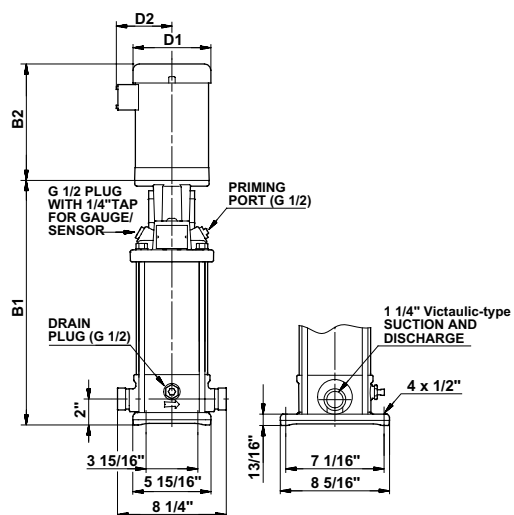

TM02 2149 4604

Dimensions and weight

| Pump Type | HP | PH | Voltage | Frame Size | CRT | | | | Ship Wt. | CRTE | | | Ship Wt. | |
|-------------|-------|----|-------------|------------|------------|--------|-------|--------|----------|--------|--------|---------|----------|----------|
| | | | | | Dimensions | | | | | D1 | D2 | B1+B2 | | Ship Wt. |
| | | | | | B1 | D1 | D2 | B1+B2 | | | | | | |
| CRT(E) 4-1 | 1/2 | 1 | 115/208-230 | 56C | 10 1/8 | 6 1/4 | 5 | 19 1/2 | 51 | 5 5/8 | 5 5/8 | 17 7/8 | 36 | |
| | | 3 | 208-230/460 | 56C | 10 1/8 | 6 1/4 | 5 | 19 1/2 | 45 | - | - | - | - | |
| CRT(E) 4-2 | 3/4* | 1 | 115/208-230 | 56C | 10 1/8 | 6 1/4 | 5 | 20 1/8 | 55 | 5 5/8* | 5 5/8* | 19 3/8* | 40* | |
| | | 3 | 208-230/460 | 56C | 10 1/8 | 6 1/4 | 5 | 19 1/2 | 48 | - | - | - | - | |
| CRT(E) 4-3 | 1 1/2 | 1 | 115/208-230 | 56C | 12 1/4 | 7 1/4 | 5 3/4 | 24 | 73 | 5 5/8 | 5 5/8 | 21 1/2 | 42 | |
| | | 3 | 208-230/460 | 56C | 12 1/4 | 7 1/4 | 5 3/4 | 23 | 61 | 7 1/8 | 6 5/8 | 23 5/8 | 67 | |
| CRT(E) 4-4 | 1 1/2 | 1 | 115/208-230 | 56C | 12 1/4 | 7 1/4 | 5 3/4 | 24 | 74 | 5 5/8 | 5 5/8 | 21 1/2 | 48 | |
| | | 3 | 208-230/460 | 56C | 12 1/4 | 7 1/4 | 5 3/4 | 23 | 62 | 7 1/8 | 6 5/8 | 23 5/8 | 68 | |
| CRT(E) 4-5 | 2 | 1 | 115/208-230 | 56C | 14 1/2 | 7 1/4 | 5 3/4 | 27 1/8 | 83 | - | - | - | - | |
| | | 3 | 208-230/460 | 56C | 14 1/2 | 7 1/4 | 5 3/4 | 26 1/4 | 71 | 7 1/8 | 6 5/8 | 25 7/8 | 74 | |
| CRT 4-6 | 3 | 1 | 115/208-230 | 182TC | 14 1/2 | 8 5/8 | 6 7/8 | 29 | 110 | - | - | - | - | |
| | | 3 | 208-230/460 | 182TC | 14 1/2 | 8 5/8 | 6 7/8 | 27 | 91 | - | - | - | - | |
| CRT 4-7 | 3 | 1 | 115/208-230 | 182TC | 16 5/8 | 8 5/8 | 6 7/8 | 31 1/8 | 110 | - | - | - | - | |
| | | 3 | 208-230/460 | 182TC | 16 5/8 | 8 5/8 | 6 7/8 | 29 1/8 | 91 | - | - | - | - | |
| CRT(E) 4-8 | 3 | 1 | 115/208-230 | 182TC | 16 5/8 | 8 5/8 | 6 7/8 | 31 1/8 | 111 | - | - | - | - | |
| | | 3 | 208-230/460 | 182TC | 16 5/8 | 8 5/8 | 6 7/8 | 29 1/8 | 92 | 7 1/8 | 6 5/8 | 29 1/2 | 85 | |
| CRT 4-10 | 5 | 1 | 208-230 | 182TC | 21 1/2 | 10 5/8 | 7 1/2 | 36 7/8 | 142 | - | - | - | - | |
| | | 3 | 208-230/460 | 182TC | 21 1/2 | 8 5/8 | 6 | 37 1/2 | 109 | - | - | - | - | |
| CRT(E) 4-12 | 5 | 1 | 208-230 | 182TC | 21 1/2 | 10 5/8 | 7 1/2 | 36 7/8 | 149 | - | - | - | - | |
| | | 3 | 208-230/460 | 182TC | 21 1/2 | 8 5/8 | 6 | 37 1/2 | 116 | 8 3/4 | 7 1/2 | 36 3/8 | 122 | |
| CRT 4-14 | 7 1/2 | 1 | 208-230 | 213TC | 25 3/4 | 10 1/4 | 7 1/2 | 41 1/8 | 165 | - | - | - | - | |
| | | 3 | 208-230/460 | 213TC | 25 3/4 | 10 1/4 | 8 1/8 | 41 1/8 | 134 | - | - | - | - | |
| CRT(E) 4-16 | 7 1/2 | 1 | 208-230 | 213TC | 25 3/4 | 10 1/4 | 7 1/2 | 41 1/8 | 167 | - | - | - | - | |
| | | 3 | 208-230/460 | 213TC | 25 3/4 | 10 1/4 | 8 1/8 | 41 1/8 | 136 | 8 3/4 | 7 1/2 | 41 3/8 | 142 | |

* 1-phase CRTE 4-2 requires 1.0 HP MLE motor.

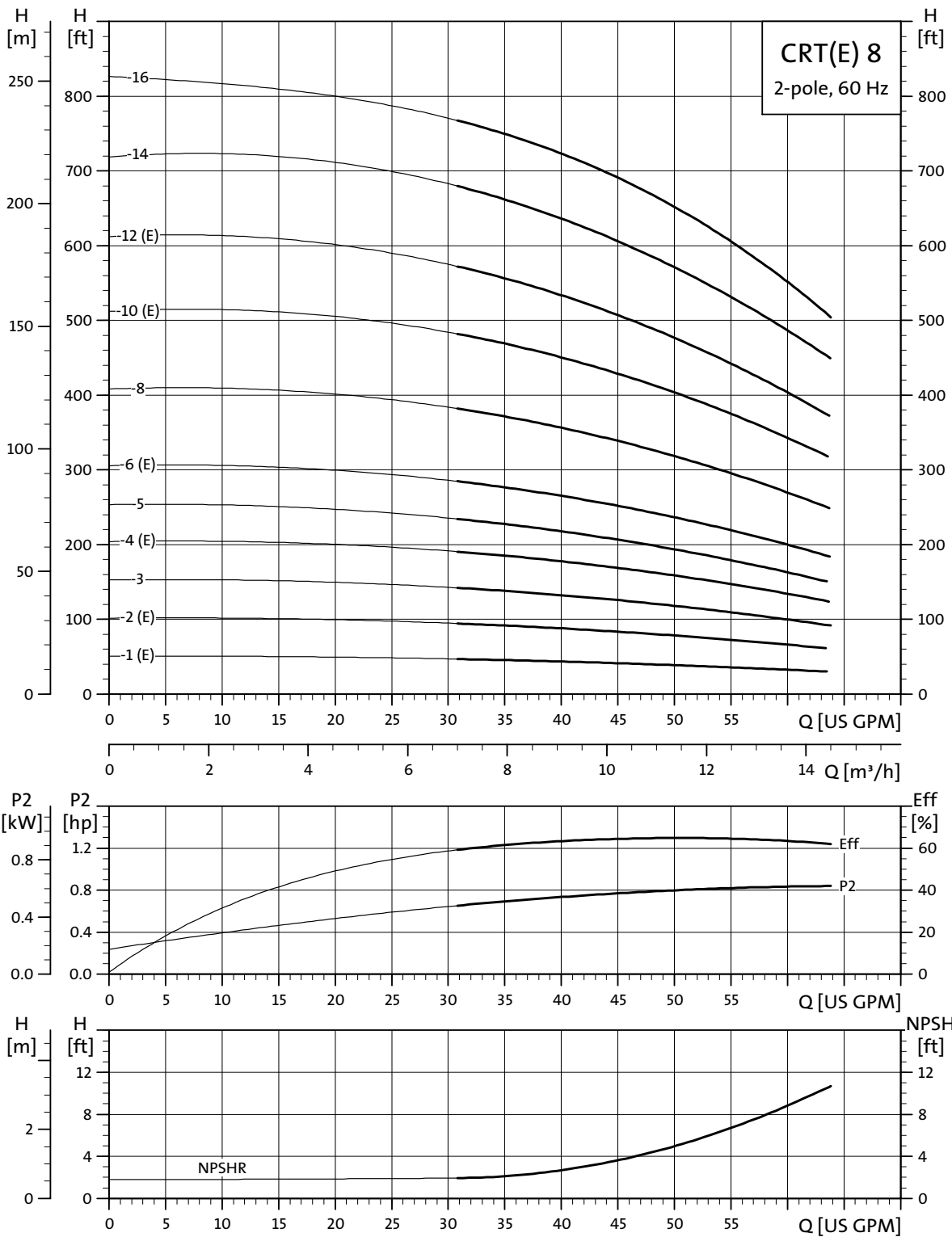

TM02 8332 0405

Dimensional sketches

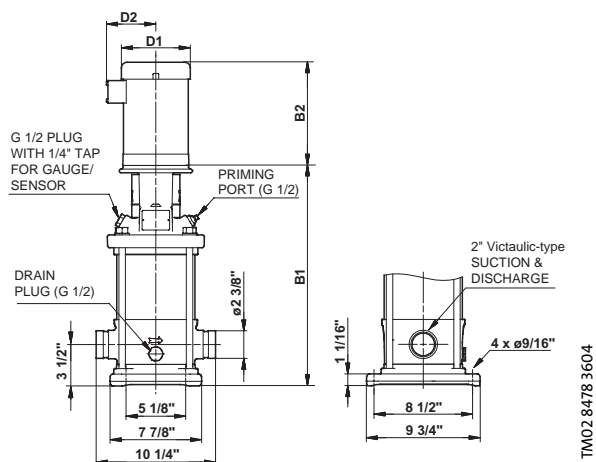

Dimensions and weight

| Pump Type | HP | PH | Voltage | Frame Size | CRT | | | | Ship Wt. | CRTE | | | Ship Wt. |
|-------------|-------|----|-------------|------------|------------|--------|--------|--------|----------|---------|---------|---------|----------|
| | | | | | Dimensions | | | | | D1 | D2 | B1+B2 | |
| | | | | | B1 | D1 | D2 | B1+B2 | | | | | |
| CRT(E) 8-1* | 3/4 | 1 | 115/208-230 | 56C | 14 1/8 | 6 1/4 | 5 | 24 1/8 | 68 | 5 5/8 * | 5 5/8 * | 23 3/8* | 53* |
| | | 3 | 208-230/460 | 56C | 14 1/8 | 6 1/4 | 5 | 23 1/2 | 61 | - | - | - | - |
| CRT(E) 8-2 | 1 1/2 | 1 | 115/208-230 | 56C | 14 1/8 | 7 1/4 | 5 3/4 | 25 7/8 | 82 | 5 5/8 | 5 5/8 | 23 3/8 | 56 |
| | | 3 | 208-230/460 | 56C | 14 1/8 | 7 1/4 | 5 3/4 | 24 7/8 | 70 | 7 1/8 | 6 5/8 | 25 1/2 | 65 |
| CRE 8-3 | 3 | 1 | 115/208-230 | 56C | 15 1/4 | 8 5/8 | 6 7/8 | 29 3/4 | 119 | - | - | - | - |
| | | 3 | 208-230/460 | 56C | 15 1/4 | 8 5/8 | 6 7/8 | 27 3/4 | 100 | - | - | - | - |
| CRT(E) 8-4 | 3 | 1 | 115/208-230 | 56C | 15 1/4 | 8 5/8 | 6 7/8 | 29 3/4 | 119 | - | - | - | - |
| | | 3 | 208-230/460 | 56C | 15 1/4 | 8 5/8 | 6 7/8 | 27 3/4 | 100 | 7 1/8 | 6 5/8 | 28 1/8 | 81 |
| CRT 8-5 | 5 | 1 | 208-230 | 56C | 19 1/2 | 10 5/8 | 7 1/2 | 34 7/8 | 150 | - | - | - | - |
| | | 3 | 208-230/460 | 56C | 19 1/2 | 8 5/8 | 6 | 35 1/2 | 118 | - | - | - | - |
| CRT(E) 8-6 | 5 | 1 | 208-230 | 182TC | 19 1/2 | 10 5/8 | 7 1/2 | 34 7/8 | 155 | - | - | - | - |
| | | 3 | 208-230/460 | 182TC | 19 1/2 | 8 5/8 | 6 | 35 1/2 | 122 | 8 3/4 | 7 1/2 | 34 3/8 | 116 |
| CRT 8-8 | 7 1/2 | 1 | 208-230 | 182TC | 24 3/8 | 10 1/4 | 7 1/2 | 39 3/4 | 183 | - | - | - | - |
| | | 3 | 208-230/460 | 182TC | 24 3/8 | 10 1/4 | 8 1/8 | 39 3/4 | 152 | - | - | - | - |
| CRT(E) 8-10 | 7 1/2 | 1 | 208-230 | 182TC | 24 3/8 | 10 1/4 | 7 1/2 | 39 3/4 | 187 | - | - | - | - |
| | | 3 | 208-230/460 | 182TC | 24 3/8 | 10 1/4 | 8 1/8 | 39 3/4 | 156 | 8 3/4 | 7 1/2 | 40 | 132 |
| CRT(E) 8-12 | 10 | 1 | 230 | 182TC | 32 3/4 | 10 1/4 | 10 3/8 | 48 5/8 | 234 | - | - | - | - |
| | | 3 | 208-230/460 | 182TC | 32 3/4 | 10 1/4 | 7 1/2 | 48 1/8 | 189 | 8 3/4 | 7 1/2 | 48 3/8 | 140 |
| CRT 8-14 | 15 | 3 | 208-230/460 | 254TC | 32 3/4 | 10 1/4 | 8 3/4 | 49 3/8 | 250 | - | - | - | - |
| CRT 8-16 | 15 | 3 | 208-230/460 | 254TC | 35 1/8 | 10 1/4 | 8 3/4 | 51 3/4 | 265 | - | - | - | - |

* 1-phase CRTE 8-1 requires 1.0 HP MLE motor.

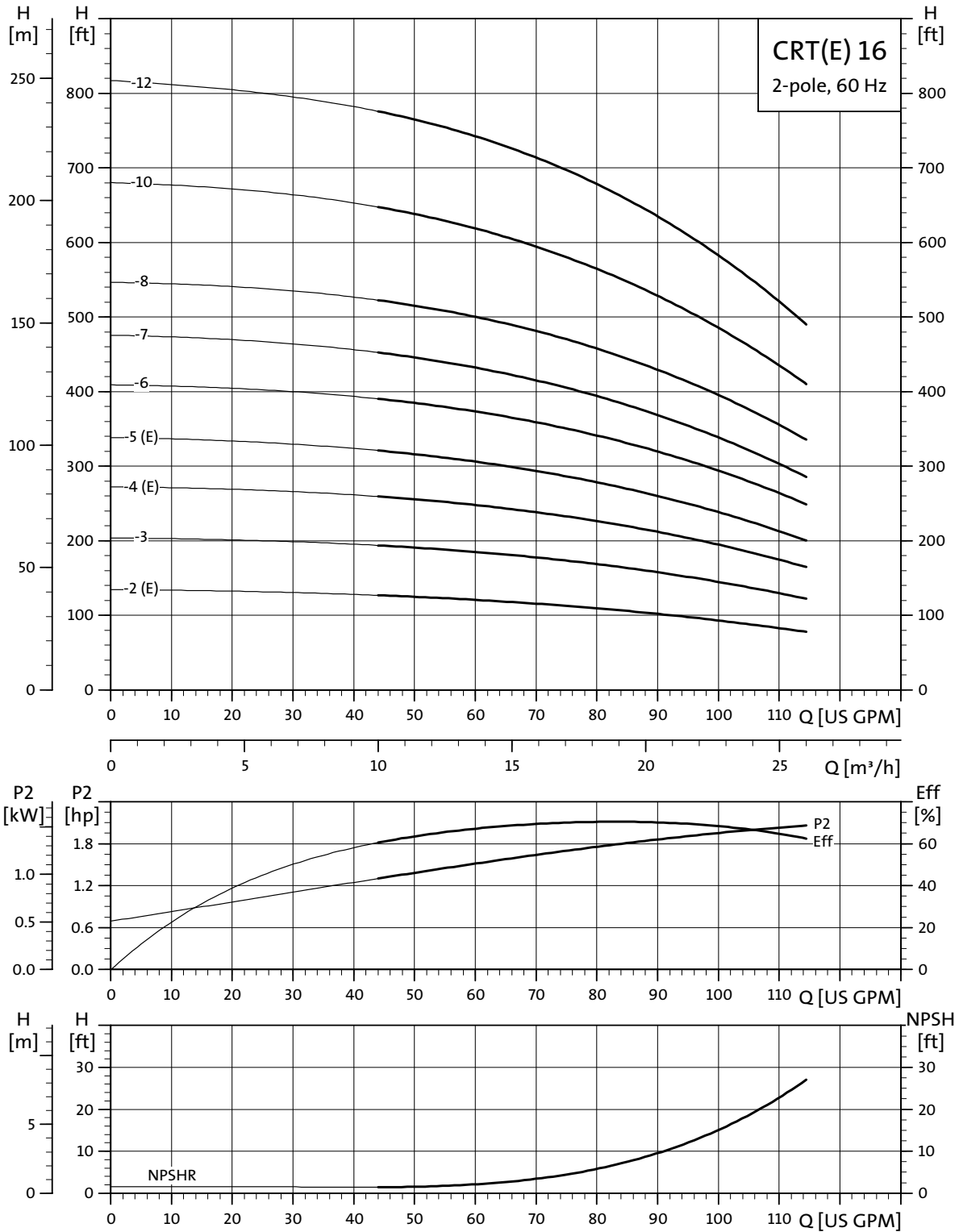

TM02 8333 0405

Dimensional sketches

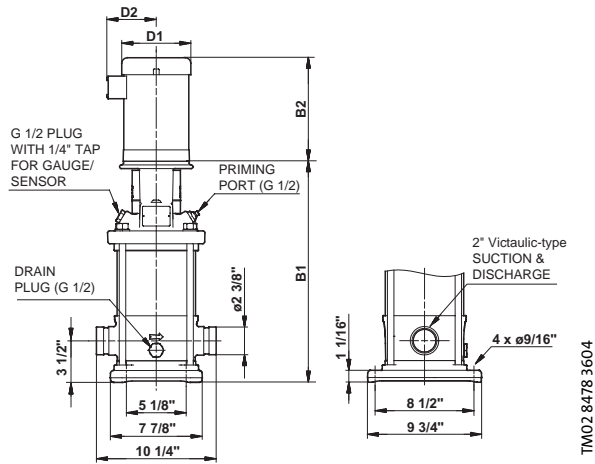

Dimensions and weight

| Pump Type | HP | PH | Voltage | Frame Size | CRT | | | | Ship Wt. | CRTE | | | |
|-------------|-------|----|-------------|------------|------------|--------|--------|--------|----------|------------|-------|--------|----------|
| | | | | | Dimensions | | | | | Dimensions | | | Ship Wt. |
| | | | | | B1 | D1 | D2 | B1+B2 | | D1 | D2 | B1+B2 | |
| CRT(E) 16-2 | 5 | 1 | 208-230 | 182TC | 18 1/4 | 10 5/8 | 7 1/2 | 33 5/8 | 147 | - | - | - | - |
| | | 3 | 208-230/460 | 182TC | 18 1/4 | 8 5/8 | 6 | 34 1/4 | 115 | 8 3/4 | 7 1/2 | 33 1/8 | 124 |
| CRT 16-3 | 7 1/2 | 1 | 208-230 | 213TC | 18 1/4 | 10 1/4 | 7 1/2 | 33 5/8 | 161 | - | - | - | - |
| | | 3 | 208-230/460 | 213TC | 18 1/4 | 10 1/4 | 8 1/8 | 33 5/8 | 131 | - | - | - | - |
| CRT(E) 16-4 | 7 1/2 | 1 | 208-230 | 213TC | 23 1/8 | 10 1/4 | 7 1/2 | 38 1/2 | 182 | - | - | - | - |
| | | 3 | 208-230/460 | 213TC | 23 1/8 | 10 1/4 | 8 1/8 | 38 1/2 | 151 | 8 3/4 | 7 1/2 | 38 3/4 | 127 |
| CRT(E) 16-5 | 10 | 1 | 230 | 213TC | 23 1/8 | 10 1/4 | 10 3/8 | 39 | 226 | - | - | - | - |
| | | 3 | 208-230/460 | 213TC | 23 1/8 | 10 1/4 | 7 1/2 | 38 1/2 | 181 | 8 3/4 | 7 1/2 | 38 3/4 | 135 |
| CRT 16-6 | 15 | 3 | 208-230/460 | 254TC | 26 5/8 | 10 1/4 | 8 3/4 | 43 1/4 | 242 | - | - | - | - |
| CRT 16-7 | 15 | 3 | 208-230/460 | 254TC | 26 5/8 | 10 1/4 | 8 3/4 | 43 1/4 | 245 | - | - | - | - |
| CRT 16-8 | 15 | 3 | 208-230/460 | 254TC | 35 | 10 1/4 | 8 3/4 | 51 5/8 | 246 | - | - | - | - |
| CRT 16-10 | 20 | 3 | 230/460 | 284TSC | 35 | 13 | 9 1/2 | 54 3/4 | 270 | - | - | - | - |
| CRT 16-12 | 25 | 3 | 230/460 | 284TSC | 42 1/8 | 13 | 9 1/2 | 61 7/8 | 337 | - | - | - | - |

Grundfos specified Baldor TEFC motors

| HP | PH | Frame | S.F. | Voltage | Mtr. Eff. % | Insul. class | KVA code | Full load current | Service factor current | Start current |
|-------|----|--------|------|-------------|-------------|--------------|----------|-------------------|------------------------|---------------|
| 1/2 | 1 | 56C | 1.6 | 115/208-230 | 62 | B | K | 7.4/4.1-3.7 | 9.8/5.2-4.9 | 39/21.6-19.5 |
| | 3 | 56C | 1.25 | 208-230/460 | 68 | B | J | 2.1-2.0/1.0 | 2.6-2.4/1.2 | 13.3-12/6.0 |
| 3/4 | 1 | 56C | 1.25 | 115/208-230 | 66 | B | K | 9.6/5.3-4.8 | 11.4/6.0-5.7 | 56/31-28 |
| | 3 | 56C | 1.25 | 208-230/460 | 74 | B | K | 2.7-2.6/1.3 | 3.1-3.0/1.5 | 16.9-15.2/7.6 |
| 1 | 1 | 56C | 1.25 | 115/230 | 66 | B | K | 12/6.0 | 14.4/7.2 | 77/38.5 |
| | 3 | 56C | 1.25 | 208-230/460 | 74 | B | J | 3.4-3.2/1.6 | 3.8-3.6/1.8 | 19.6-17.8/8.9 |
| 1 1/2 | 1 | 56C | 1.3 | 115/208-230 | 71 | B | K | 17/9.5-8.6 | 20.4/11.3-10.2 | 106/58.6-53 |
| | 3 | 56C | 1.15 | 208-230/460 | 75.5 | B | G | 5.0-4.6/2.3 | 5.4-5.2/2.6 | 35.4-32/16 |
| 2 | 1 | 56C | 1.15 | 115/230 | 74 | F | K | 23/11.5 | 25.4/12.7 | 156/78 |
| | 3 | 56C | 1.15 | 208-230/460 | 78.5 | B | H | 5.7-5.4/2.7 | 6.5-6.2/3.1 | 38.7-35/17.5 |
| 3 | 1 | 182TC | 1.15 | 115/208-230 | 75 | F | H | 29/16-14.5 | 31.8/18-15.9 | 170/94-85 |
| | 3 | 182TC | 1.15 | 208-230/460 | 81.5 | F | K | 8.2-7.8/3.9 | 9.0-8.6/4.3 | 77.4-70/35 |
| 5 | 1 | 213TC | 1.15 | 208-230 | 80 | F | J | 24-22 | 27-25 | 188-170 |
| | 3 | 184TC | 1.15 | 208-230/460 | 85.5 | F | K | 13.2-12/6.0 | 15-13.6/6.8 | 104-94/47 |
| 7 1/2 | 1 | 213TC | 1.15 | 208-230 | 82 | F | F | 33.8-31 | 38.5-35.5 | 244-220 |
| | 3 | 213TC | 1.15 | 208-230/460 | 87.5 | H | L | 19-17.2/8.6 | 21.7-19.6/9.8 | 169-152/76 |
| 10 | 1 | 213TC | 1.15 | 230 | 85.5 | F | F | 40 | 46 | 284 |
| | 3 | 213TC | 1.15 | 208-230/460 | 85.5 | F | J | 25-24/12 | 28.3-27.2/13.6 | 233-210/105 |
| 15 | 3 | 254TC | 1.15 | 208-230/460 | 86.5 | H | L | 38-34/17 | 43.4-39/19.5 | 376-340/170 |
| 20 | 3 | 284TSC | 1.15 | 230/460 | 89.5 | F | H | 46/23 | 52.4/26.2 | 320/160 |
| 25 | 3 | 284TSC | 1.15 | 230/460 | 91.7 | F | J | 57/28.5 | 66/33 | 498/249 |



Notes:

- The information in this chart applies to **Grundfos' specified Baldor® motors**.
Grundfos CR pumps are supplied with heavy-duty 2-pole, NEMA C-frame motors built or selected to our rigid specifications. All CR pump motors have heavy-duty bearings in them for maximum thrust requirements.
It is not recommended that an off-the-shelf standard Baldor motor be used on a Grundfos pump. Ideally, the best motor choice would be the Grundfos specified motor.
- Other motor types are available (i.e., Explosion proof, Mill and Chem duty, High Efficiency, etc.), consult local Grundfos company for more information.
- Pumps supplied by Grundfos Canada are normally supplied with motors from other manufactures. 575 volt motors meet EAct/NRC efficiency standards. Dimensions and data will vary, contact local Grundfos company for more information.
- All values are subject to change without notice.

MLE motors

| HP | PH | MLE Frame | MLE S.F. | MLE Voltage | MLE Mtr. Eff. % | MLE Insul. class | MLE Full load current | MLE service Factor current |
|-------|----|-----------|----------|-------------|-----------------|------------------|-----------------------|----------------------------|
| 1/2 | 1 | 56C | 1.0 | 208-230 | 71.0 | F | 2.8 | 2.8 |
| 3/4 | 1 | 56C | 1.0 | 208-230 | 74.0 | F | 3.9 | 3.9 |
| 1 | 1 | 56C | 1.0 | 208-230 | 76.0 | F | 5.2 | 5.2 |
| | 3 | 56C | 1.25 | 460-480 | 77.0 | F | 1.7 | 2.1 |
| 1 1/2 | 1 | 56C | 1.0 | 208-230 | 77.0 | F | 7.5 | 7.5 |
| | 3 | 56C | 1.15 | 460-480 | 80.0 | F | 2.2 | 2.6 |
| 2 | 3 | 56C | 1.15 | 460-480 | 82.0 | F | 2.8 | 3.2 |
| 3 | 3 | 182TC | 1.15 | 460-480 | 83.0 | F | 4.0 | 4.6 |
| 5 | 3 | 184TC | 1.15 | 460-480 | 84.0 | F | 6.5 | 7.5 |
| 7 1/2 | 3 | 215TC | 1.15 | 460-480 | 85.0 | F | 9.6 | 11.0 |
| 10 | 3 | 215TC | 1.15 | 460-480 | 86.5 | F | 12.2 | 14.0 |



GR 8972_p

Note: MLE MTR Eff. Is the total efficiency for the motor and variable frequency drive.

Pipework connection

PJE couplings for CRT(E)

A set includes 1 coupling, 1 gasket, 1 pipe stub and bolts and nuts.

| Pump type | Pipe stub | Pressure rating | Pipework connection | Number of coupling sets needed | Material number | |
|------------------------|-------------|-----------------|---------------------|--------------------------------|-----------------|----------|
| | | | | | EPDM | FKM |
| CRT(E) 2 and CRT(E) 4 | Threaded | 1015 psi | 1.25" NPT | 2 | 415522 | 91134571 |
| CRT(E) 8 and CRT(E) 16 | For welding | 1015 psi | 1.25" | 2 | 415521 | 415539 |
| CRT(E) 2 and CRT(E) 4 | Threaded | 1015 psi | 2" NPT | 2 | 336924 | 91134572 |
| CRT(E) 8 and CRT(E) 16 | For welding | 1015 psi | 2" | 2 | 425934 | 425952 |

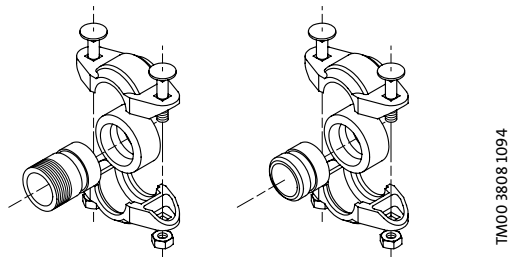

Fig. 15 PJE couplings

ANSI flange adapter for CRT(E)

For pipework connection, Grundfos can offer an ANSI flange adapter set.

A set includes one flange adapter and one gasket, two sets are normally required. The set does not include connection nuts and bolts. Four 5/8" x 3" bolts and nuts are required for each adapter set.

| Pump type | Pipework connection | EPDM |
|---------------------|---------------------|----------|
| CRT(E) 8, CRT(E) 16 | ANSI 2" 150 lb. | 91122697 |

Lists of variants - on request

Although the Grundfos CRT(E) product range offers a number of pumps for different applications, customers require specific pump solutions to satisfy their needs.

To the side please find the range of options available for customizing the CRT(E) pumps to meet the customers' demands.

Contact Grundfos for further information or for requests other than the ones mentioned below.

Motors

| Variant | Description |
|---|---|
| Explosion proof (including ATEX approved) | For operation in hazardous atmospheres, explosion-proof or dust-ignition-proof motors may be required. |
| Motors with anti-condensation heating unit | For operation in humid environments motors with built-in anti-condensation heating may be required. |
| Efficiency class | <ul style="list-style-type: none"> • EPAct/NRC—motor efficiency according to EPAct/NRC standards • Premium efficiency |
| Integrated variable speed drive | All Grundfos CRT pumps 10 hp and below are available as standard with integrated variable speed drive (type MLE) motors. |
| Oversized motors | Ambient temperatures above 104°F or installation at altitudes of more than 3,300 feet above sea level require the use of oversized motors (i.e. derating). |
| 4-pole motors | Grundfos offers standard motors fitted with 4-poles. |
| Different enclosure class | <p>As standard, Grundfos can supply:</p> <ul style="list-style-type: none"> • ODP: open drip-proof; TEFC: total-enclosed fan-cooled <p>On request, we can supply:</p> <ul style="list-style-type: none"> • Chemical processing/mill and chem duty • Washdown duty (Up through 10 hp only) • Other |

Shaft seals

| Variant | Description |
|--|--|
| Shaft seal with FKM or FFKM O-ring material | Shaft seals with FKM or FFKM o-ring material are recommended for applications where the pumped liquid may damage the standard O-ring material. |
| Shaft seal with SiC/SiC | Grundfos offers shaft seals with silicon carbide/silicon carbide (SiC/SiC). |

Pumps

| Variant | Description |
|-----------------------------------|--|
| Horizontally mounted pumps | For safety or height reasons, certain applications, for instance on ships, require the pumps to be mounted in the horizontal position. For easy installation the pumps are equipped with brackets that support motor and pump. |
| Pumps with bearing flange | The bearing flange is suitable for applications where the inlet pressure is higher than the maximum pressure recommended. The bearing flange increases the life of motor bearings. (Recommended for standard motors). |
| Belt-driven pumps | Belt-driven pumps designed to operate in places with limited space or where no electrical power is available. |

Further product documentation

Sources of product documentation

In addition to the printed Product Guide, Grundfos offers the following sources of product documentation.

- WinCAPS®
- WebCAPS®.

WinCAPS®

WinCAPS is a **Windows-based Computer-Aided Product Selection** program containing information on more than 90,000 Grundfos products.

Available on CD-ROM in more than 15 languages, WinCAPS offers

- detailed technical information
- selection of the optimum pump solution
- dimensional drawings of each pump
- detailed service documentation
- installation and operating instructions
- wiring diagrams of each pump.



Fig. 16 WinCAPS CD-ROM

cd-wincaps

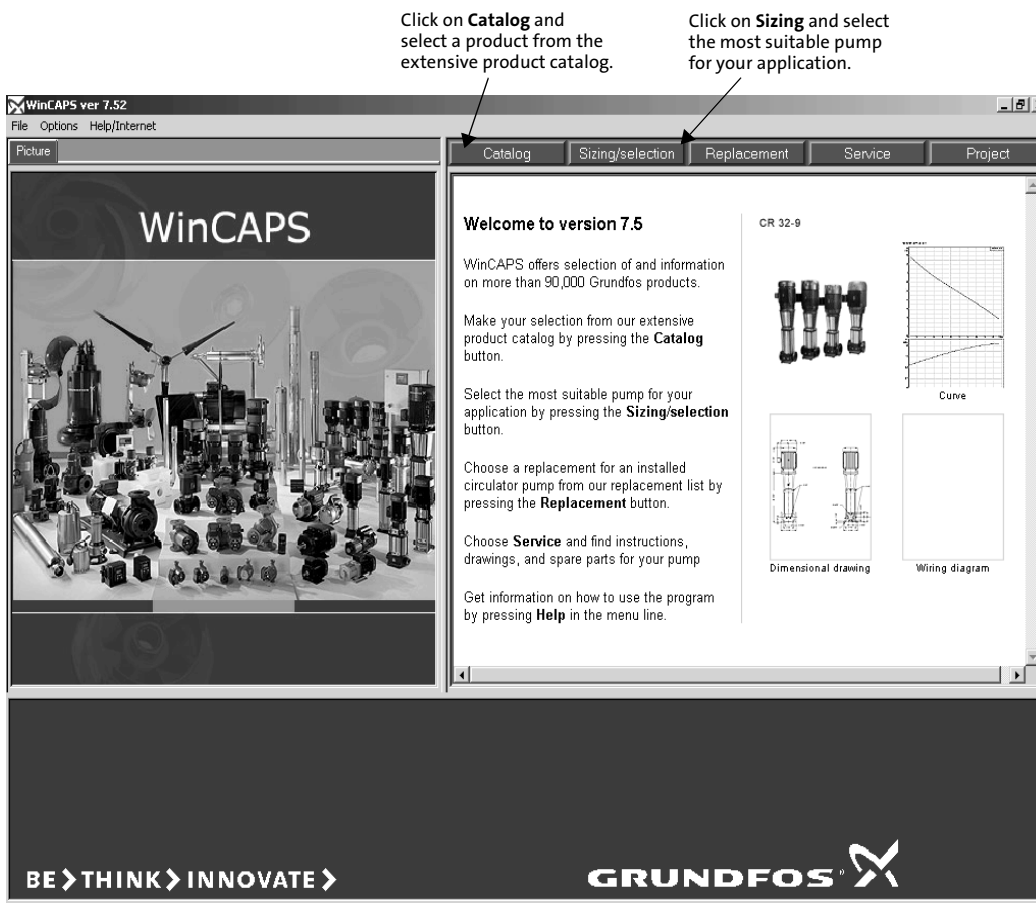

Click on **Catalog** and select a product from the extensive product catalog.

Click on **Sizing** and select the most suitable pump for your application.

Fig. 17 WinCAPS

WinCAPS_US

Further product documentation

WebCAPS®

WebCAPS is a **Web**-based **Computer Aided-Product Selection** program and a web-version of WinCAPS.

Available on Grundfos' homepage, www.grundfos.com, WebCAPS offers

- detailed technical information
- dimensional drawings of each pump
- wiring diagrams of each pump.

The screenshot shows the WebCAPS website interface in a Microsoft Internet Explorer browser window. The browser title bar reads "WebCAPS 2.40.03 Customized for Grundfos - 60 Hz - USA - Microsoft Internet Explorer provided by Grundfos". The website header includes the "WebCAPS" logo and the "GRUNDFOS" logo. Below the header is a navigation bar with tabs for "Product selection", "Literature", and "CAD Drawings". Below the navigation bar are buttons for "Catalog", "Replacement", "Product search", and "Service". On the right side of the navigation bar are links for "Login", "Unit", and "Language". Below the navigation bar are dropdown menus for "USA" and "60 Hz". The main content area features a large "WebCAPS" heading and a sub-heading "Computer Aided Product Selection". Below this is a large image of various Grundfos pumps. To the right of the image is a sidebar with the product name "DME12-6" and three icons: "Curve", "Dimensional Drawing", and "Wiring Diagram". Below the image and sidebar is a list of bullet points: "• make your selection from our extensive product catalog ...", "• choose a replacement for an installed circulator pump from our 50 Hz replacement list", and "• Choose service and find instructions, drawings, and spare parts for your pump".

Click **Catalog** and select a product from the extensive product catalog.

Click **Replacement** and select the right replacement pump based on the current installation.

Click **Literature** to select and download Grundfos documentation by browsing the product ranges or performing a specific search. The literature includes:
- Data booklets
- Installation and operating manuals
- Service etc.

Click **Product search** and select a product from the extensive product catalog.

Click **Service** to find information on service kits and spare parts.

Being a registered user click **Log in** to:
- save your settings
- define and save your own units
- save personalized information.

Click **Units** and select your preferred units of measurement:
- Default units
- SI units
- US units.

Click **Language** and select your preferred language.

WebCAPS offers selection of and information on more than 60,000 Grundfos products

- make your selection from our extensive product catalog ...
- choose a replacement for an installed circulator pump from our 50 Hz replacement list
- Choose service and find instructions, drawings, and spare parts for your pump

Fig. 18 WebCAPS

WebCAPS_US

| | | |
|-------------|-------|----|
| L-CRT-PG-01 | 02/05 | US |
| | | |

Subject to alterations.